



## SUPER SEAM II

Super Seam II is a snap sealed standing seam roof panel.

It is available in 24 gauge only.

- UL Construction No. 180B, 205, 205A, 286, 303B, 534, 535, 536, 537, 541

- UL 580 Up-Lift tested / Class 90 Rated
- UL 2218 Hail Impact Resistant Tested Inclined: Unlimited / Impact Class 4
- Florida Product Approval\*



### Self-Storage Project

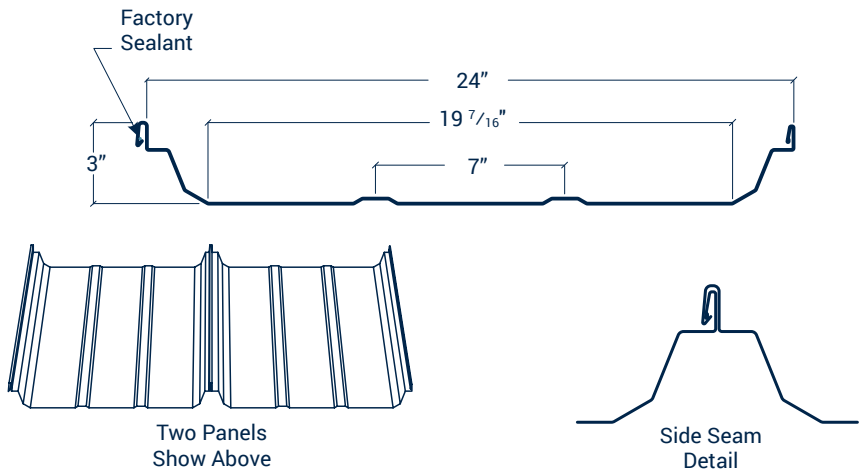

DESIGN PROPERTIES								
Panel Gauge	Fy (KSI)	Weight (PSF)	NEGATIVE BENDING			POSITIVE BENDING		
			lxe (IN. 4/FT.)	Sxe (IN. 3/FT.)	Maxo (KIP-IN.)	lxe (IN. 4/FT.)	Sxe (IN. 3/FT.)	Maxo (KIP-IN.)
26	50	1.02	0.1025	0.0694	2.0764	0.2202	0.0901	2.6987
24	50	1.23	0.1355	0.0951	2.8477	0.2803	0.1156	3.4612
22	50	1.56	0.1837	0.1332	3.9877	0.3640	0.1504	4.5020

**NOTES:**

1. All calculations for the properties of Super Seam II panels are calculated in accordance with the North American Specification For Design Of Cold-Formed Steel Structural Members.