



**WHIRLWIND STEEL**  
BUILDINGS & COMPONENTS



# WHIRLWIND

BUILDING  
SYSTEMS



---

## OUR STORY

Family owned and operated since 1955, Whirlwind Steel is proud to have served the needs of contractors, builders, architects, businesses, governmental organizations, and consumers. Our discerning customers have turned to Whirlwind Steel with confidence for pre-engineered metal buildings and components including panels, primary and secondary structural framing, roofing, solar racks plus a full line of metal building accessories and trims. Both welded and cold-form steel framing is done by fully trained professionals and our quality control team is the best in the industry. Now is

the time for you to find out why so many people have trusted Whirlwind Steel with their most important projects for so long.

### TODAY

With two 250,000 square foot manufacturing facilities – the original plant in Houston and a second in Tallapoosa, Georgia – Whirlwind Steel continues to be an industry leader. Over 200,000 buildings and projects can be found in every US state as well as other countries. We are proud of our legacy and encourage you to call us and discuss your next project today.

## OUR CORE VALUES

At the heart of all that we do is to provide a building experience and focus on relationship that's second to none, so we've developed our business around six core values that help us live up to our mission – to build for life.

**R**

### RELATIONSHIPS WITH MUTUAL RESPECT

Mutual respect is the key to mutual success. Honesty, integrity and fairness for all.

**A**

### ACT WITH PURPOSE

We hold ourselves to the highest level of accountability so our customers, coworkers and suppliers will be confident that we'll do what we say we will, every time.

**P**

### PASSION FOR LIFE

We develop lifelong relationships with our customers, coworkers and suppliers, making sure that we deliver on time, without compromising safety.

**I**

### INNOVATE AT EVERY LEVEL

We don't just accept change. We embrace it. Our company was built on an entrepreneurial spirit. Innovation from within has been a key element to our success.

**D**

### DEDICATION TO EXCELLENCE

We're committed to excellence in every part of our business. We are focused on providing industry leading product quality, efficiency and customer service.

**C**

### CREATE RAVING FANS

We go above and beyond to ensure an exceptional experience.  
We create raving fans!





# WHY WHIRLWIND STEEL

## Cost Efficient

Because each building is custom engineered to meet specific requirements, you avoid waste while maximizing cost efficiency.

## Longevity

Intended to last decades, metal buildings meet the strictest construction standards. Whirlwind products are tested for hail impact, fire, wind driven rain, snow loads and high velocity winds.



---

# MANUFACTURING PROCESS



## Experienced Professionals

With 800+ staff of professional experience that have delivered over 15,000 buildings, you can expect the most efficient, attractive and economical solution for your next project.

---

## Internal Design Professionals

We are committed to providing safe, sound and serviceable structures by using our in-house team of highly trained engineering and drafting professionals.

---

## Fabrication Excellence

You can expect a building fabricated to the highest industry standards. We undergo an annual and stringent accreditation process for metal building manufacturers by the IAS.

---

## Shipping and Transportation

Your building will be carefully loaded, secured and shipped to the job site in the most efficient and reliable way possible. Start construction with a complete order delivered on time to your job site.

---

## Customer Service

You and your building erector will find Whirlwind's experienced customer service team available before, during and after construction to ensure the job gets done right and finished on time

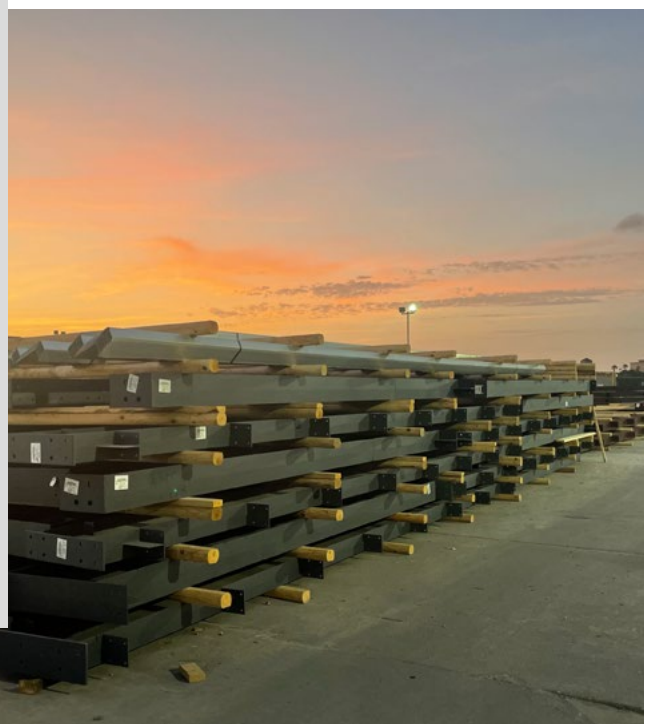



# 01 PRE-ENGINEERED METAL BUILDINGS

The unique benefits of pre-engineered metal buildings are well known to contractors, erectors, architects and the people who use and work in these buildings. Experience counts when it comes to designing and manufacturing a metal building, and making sure the work is done in a timely and economical manner. That's why Whirlwind Steel has been the partner of choice on over 240,000 projects during our 65 years as a family run business. And we understand how important it is that everyone involved with a metal building project have a basic understanding of how our pre-engineered metal buildings work.

**End frames can be expandable or not.**

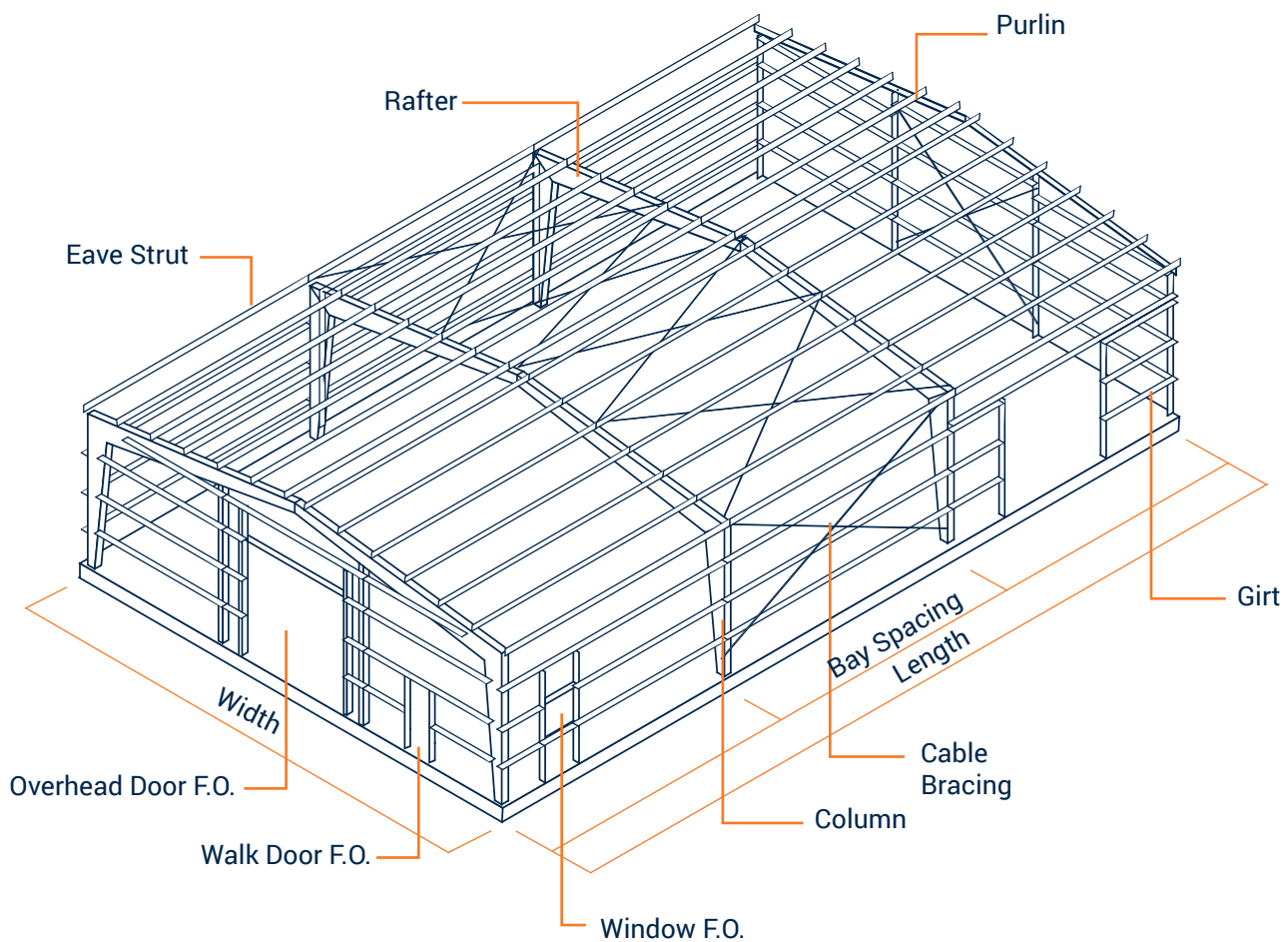

# 02 FRAME TYPES

Welded framing ensures the strongest and most durable structure. A sample of the most common frame types are described below. An important feature of a pre-engineered metal building is the flexibility to mix and match these frames to create custom designs for most applications.

## Lean-To (LT)

LT buildings are ideal for use as office structures attached to larger WRF or CB buildings.

LT framing is an economical solution for expanding existing buildings.

Simple span frame design provides minimal horizontal thrust so foundation costs are minimized.

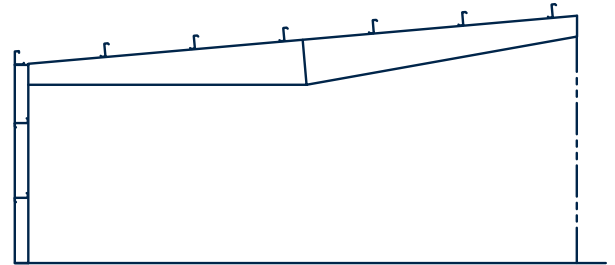

## Single Sloped Welded Rigid Frame (SSRF)

SSRF buildings are ideal where drainage restrictions are an issue, such as strip mall shopping centers.

SSRF buildings are available with options such as straight columns and/or interior columns.

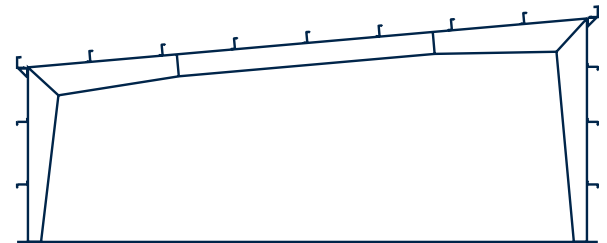

## Welded Tapered Beam (WTB)

WTB buildings provide maximum floor space.

Straight sidewalls allow interior finishes to be installed easily.

WTB design minimizes the horizontal frame base reaction so less expensive foundations may be used.

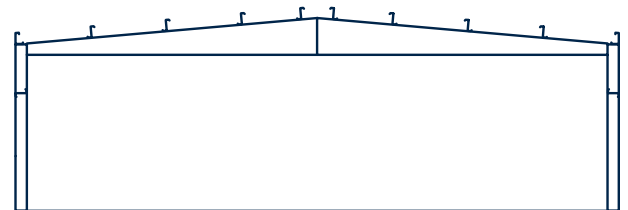

## Welded Rigid Frame (WRF)

WRF buildings provide for the widest possible spans without interior columns.

WRF buildings are economical due to the use of tapered members.

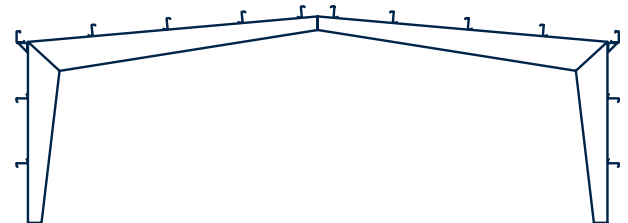

## Column And Beam (CB)

CB frames are ideal when wide buildings are required and interior columns are required.

CB frames may be used with bar joist roof purlins when large column free areas are required.

Interior columns may be recessed for a clean appearance.

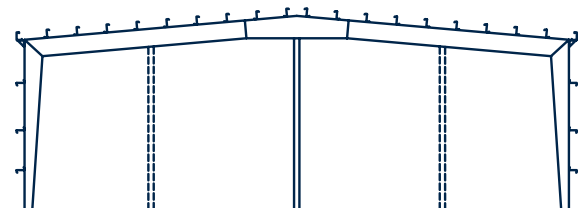

### By-Pass vs. Flush Girt

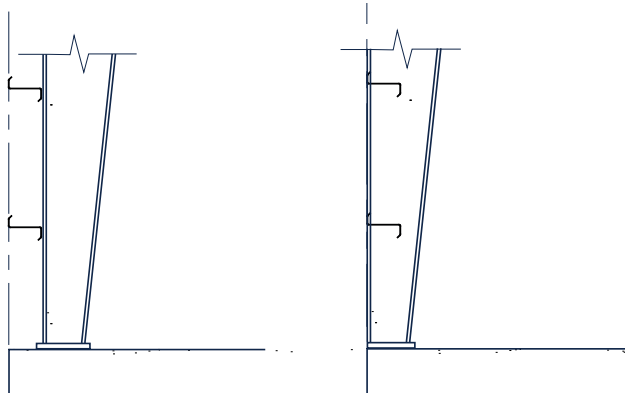

### Tapered vs. Straight Column

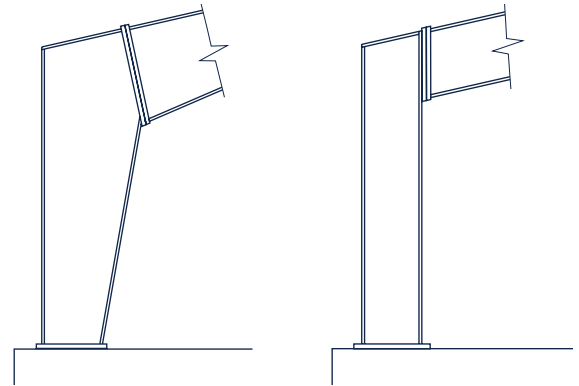

## 03 ROOF & WALL PANELS

One of our most popular and flexible panel choices, Whirlwind Steel's Super Span X, can be used for both wall and roofing applications. Super Span X gives you a full line of trim, hardware and accessories to customize your metal building project. Whirlwind Steel offers the industry standard steel gauges, 26 and 24, in a variety of colors that provide the highest quality paint finishes. We also offer both heavier and lighter gauges when called for, just ask your sales manager for other options. Depending on your choice of products, warranties are available for up to 40-years.

Fasteners

Wall Panel

**Install Top & Bottom fastener line first before securing middle of panel.**

**WARNING!**  
To prevent rust, leave a 1/8" gap where the panel meets the base trim.

Wall Panel

Base Angle

Base Trim

Anchor Bolts

Concrete foundation and anchor bolts not provided by Whirlwind.

Roof Panel

Fastener

Fastener

Rope seal

Panel to be Installed

Secured Roof Panel

Sheeting Direction



SUPER SPAN X

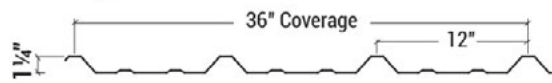

Super Span can be used for wall and roof applications. It is available in 26, 24, and 22 gauge.

- UL Construction No. 30, 79, 161, 167
- UL 580 Up-Lift tested / Class 90 Rated
- UL 2218 Hail Impact Resistant Tested Inclined: Unlimited / Impact Class 4
- Texas Department of Insurance \*
- Florida Product Approval\*
- Dade County NOA\*



Low Rib can be used for wall and roof applications.

It is available in 26, 24, and 22 gauge.

- UL Construction No. 39
- UL 580 Up-lift tested/ Class 90 Rated
- UL 2218 Hail Impact Resistant Tested Inclined: Unlimited / Impact Class 4
- Texas Department of Insurance\*
- Florida Product Approval\*



LOW RIB X

COR-SPAN X

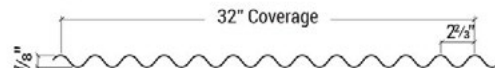

Cor-Span can be used for wall and roof applications.

It is available in 26, 24, and 22 gauge. It is an excellent choice for self storage corridors.

- UL 2218 Hail Impact Resistance
- Texas Department of Insurance\*

\* Contact Your Sales Representative for Current Pricing and Availability

COMMERCIAL & INDUSTRIAL  
PANEL PROFILES





7.2N Rib can be used for wall and roof applications.

It is available in 26, 24, and 22 gauge.

- UL Construction No. 244
- UL 580 Up-lift tested/ Class 90 Rated
- UL 2218 Hail Impact Resistant Tested  
Inclined: Unlimited / Impact Class 4
- Florida Product Approval\*



7.2N RIB

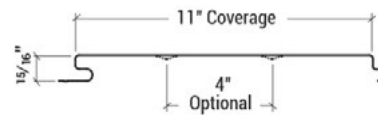

Accent II is a concealed fastener soffit/liner panel.

It is available in 24 gauge only.

ACCENT-11 & 11R

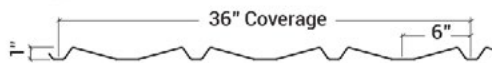

Monarch is a wall panel.  
It is available in 26, and 24 gauge.



MONARCH X

Featuring warranties up to 40-years, each of these products offer a full line of trim, hardware and accessories. Whirlwind provides only the highest quality paint finishes, including 14 that are intended to improve energy efficiency. Color charts are available for all products.

SUPER SEAM PLUS

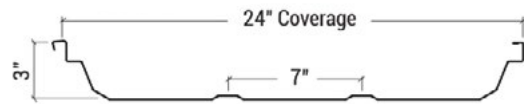

Super Seam Plus is a mechanically seamed roof panel. It is available in 24 gauge only.

- UL Construction No. 180C, 287, 308A, 450, 538, 539, 540
- UL 580 Up-Lift tested / Class 90 Rated
- UL 2218 Hail Impact Resistant Tested Inclined: Unlimited / Impact Class 4
- Florida Product Approval\*

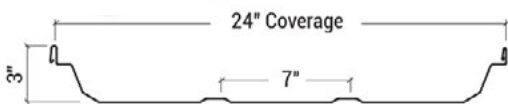

Super Seam II is a snap sealed standing seam roof panel.

It is available in 24 gauge only.

- UL Construction No. 180B, 205, 205A, 286, 303B, 534, 535, 536, 537, 541
- UL 580 Up-Lift tested / Class 90 Rated
- UL 2218 Hail Impact Resistant Tested Inclined: Unlimited / Impact Class 4
- Florida Product Approval\*



SUPER SEAM II

SHADOW WALL

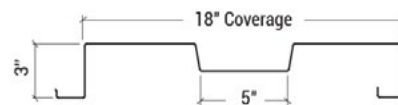

Shadow Wall is a concealed fastener wall panel. It is available in 24 gauge only.

\* Contact Your Sales Representative for Current Pricing and Availability

STANDING SEAM & ARCHITECTURAL  
**PANEL PROFILES**

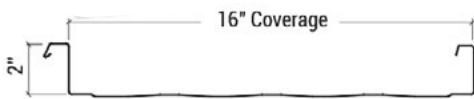

Weather Lok-16 is a mechanically seamed roof panel.

It is available in 24 gauge only.

- UL Construction No. 506, 506A, 506B
- UL 580 Up-Lift tested / Class 90 Rated
- UL 2218 Hail Impact Resistant Tested  
Inclined: Unlimited / Impact Class 4
- Texas Department of Insurance\*
- Florida Product Approval\*
- Dade County NOA\*



WEATHER LOK-16

WEATHER SNAP-16



Weather Snap-16 is a snap seamed roof panel.  
It is available in 24 gauge only.

- UL Construction No. 254, 255, 261, 303, 342, 343, 414, 436, 445, 446, 447, 448, 486, 508A, 543, 544
- UL 580 Up-Lift tested / Class 90 Rated
- UL 2218 Hail Impact Resistant Tested  
Inclined: Unlimited / Impact Class 4
- Texas Department of Insurance\*
- Florida Product Approval\*

## OUR COATING SYSTEM

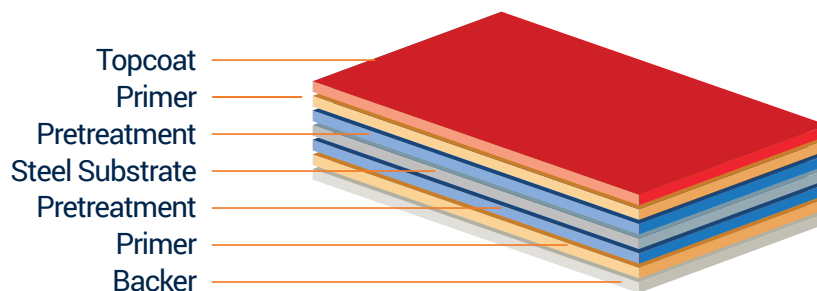









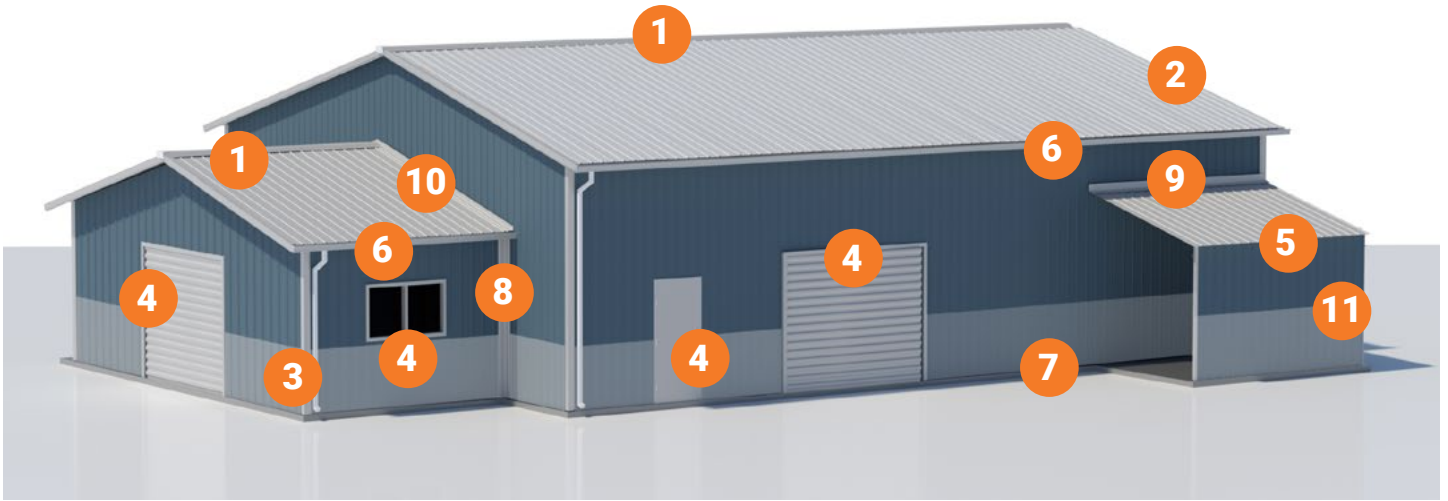

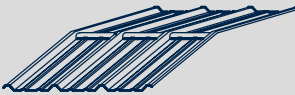
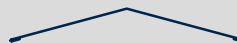



Featuring warranties up to 40-years, each of these products offer a full line of trim, hardware and accessories. Whirlwind provides only the highest quality paint finishes, including 8 different colors of which 6 are especially intended to improve energy efficiency. Color charts are available for all products.



# 04 TRIM PARTS

Whirlwind gives you a full line of trim, hardware and accessories to customize your metal building project. Featuring a wide selection of colors, you'll find no one offers a better selection of trim – from the ground to the roof ridge – to finish your building design just the way you want. In fact, the trim displayed here is only a very small selection of our extensive offering of trim conditions.



<p><b>1</b> Die Formed Ridge Cap 50SSRC</p> 	<p>Hip Trim HF-120</p> 	<p>Ridge Roll MT-80</p> 	<p><b>2</b> Rake Trim FL-16 RT-101 RT-801</p> 	
<p><b>3</b> Corner Trim CT-102</p> 	<p><b>4</b> Head &amp; Jamb Trim FL-26 JT-101</p> 	<p><b>5</b> Eave Trim ET-80 ET-70</p> 		
<p><b>6</b> Gutter Trim FL-18D</p> 	<p>FL-18B</p> 	<p>GU-12</p> 	<p>GU-80</p> 	<p><b>7</b> Base Trim FL-72</p> 
<p><b>8</b> Inside Corner ICT-801</p> 	<p><b>9</b> Transition Trim MT-70</p> 	<p><b>10</b> Sidewall Trim MT-101</p> 	<p><b>11</b> Wainscot Trim WT-101</p> 	

# 05 INSULATION OPTIONAL

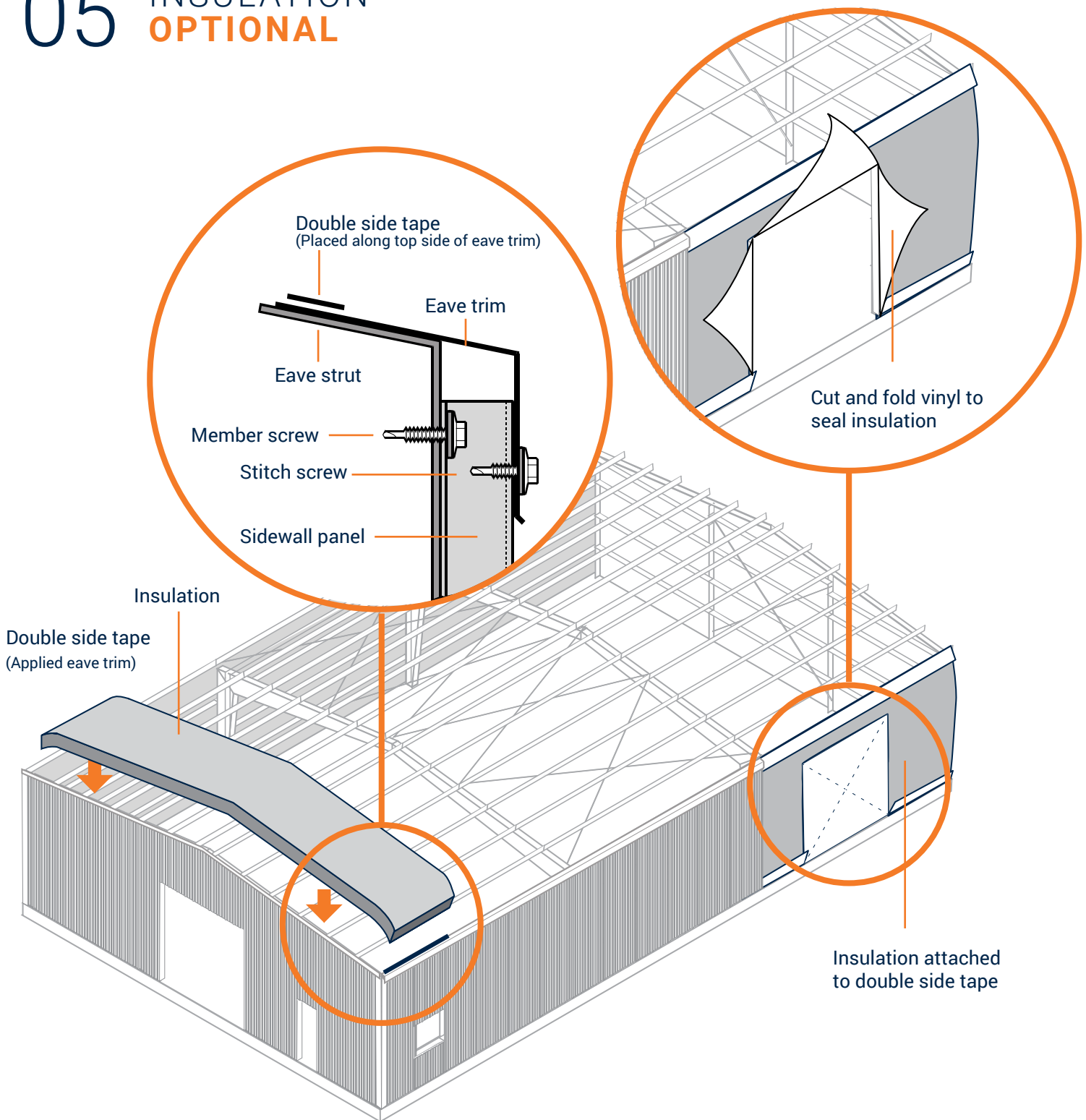

Whirlwind Steel has partnerships with name brand suppliers of metal building insulation that have the experience and service capabilities to meet our customers' needs. Our customers can also choose to work directly with insulation manufacturers. The coordination between Whirlwind and outside vendors should be carefully discussed with your sales manager to ensure there are no delays at the job site when construction starts on your pre-engineered metal building.

# 06 FRAMED OPENINGS

## Overhead / Roll Up Doors

### Overhead Doors Roll Up Doors and Walk Doors

Overhead and Roll Up doors come in a variety of heights and widths requiring careful planning. Overhead and Roll-up doors need extra headroom to accommodate doors that are either rigid or flexible. Additionally, mechanical doors often require additional headroom to allow for motors and other accessories.

While Whirlwind Steel does not manufacture doors, we can provide a variety of solutions based on your needs. It is important to note that metal buildings should use steel reinforced commercial doors and not those typically found in residential construction. This also applies to both manual and electrical roll up and overhead doors. All doors, whether provided by Whirlwind or supplied by our clients, should be discussed early in the design process.

### Windows

Window openings can be created using both traditional and custom shapes in most any size. Like doors, though Whirlwind Steel does not manufacture windows we can provide a variety of solutions based on your needs. Or, you can arrange to supply windows and frames. There can be many decisions to consider early in the design process and the help of our experienced sales managers will be important to getting your building project done right and on time.

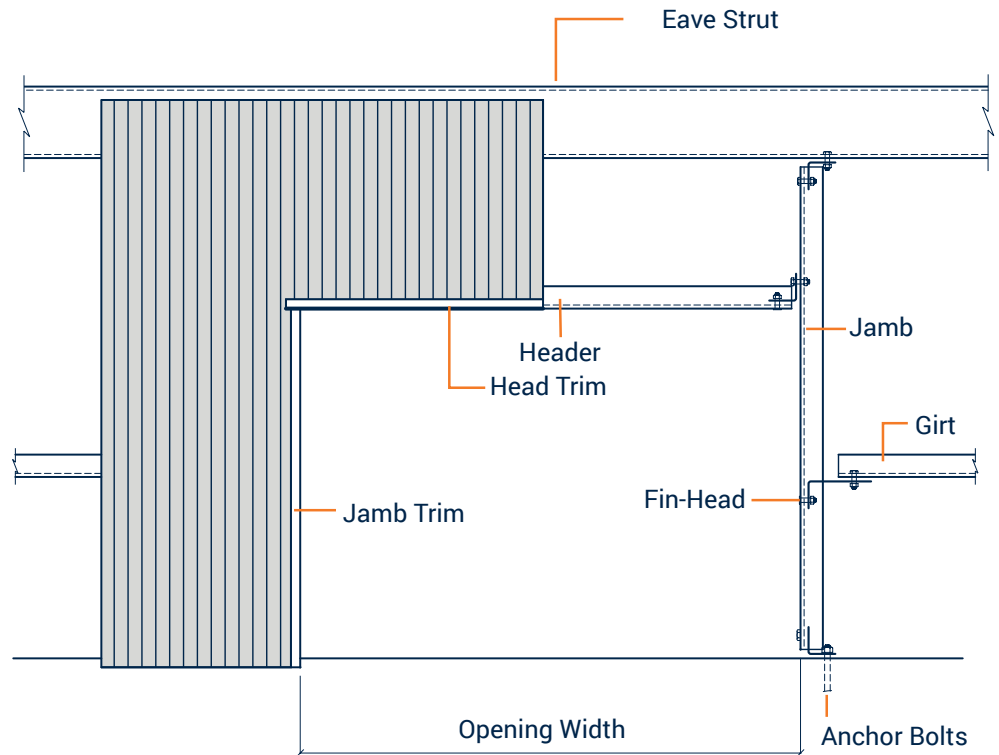

Concrete foundation and anchor bolts not provided by Whirlwind.

### Headroom Clearances

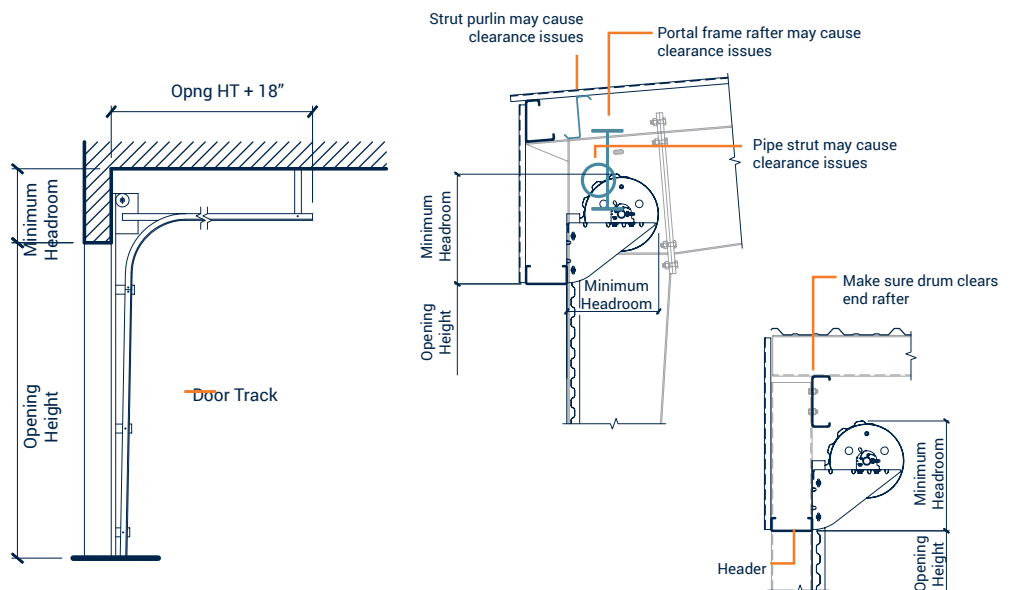



## Walk Doors

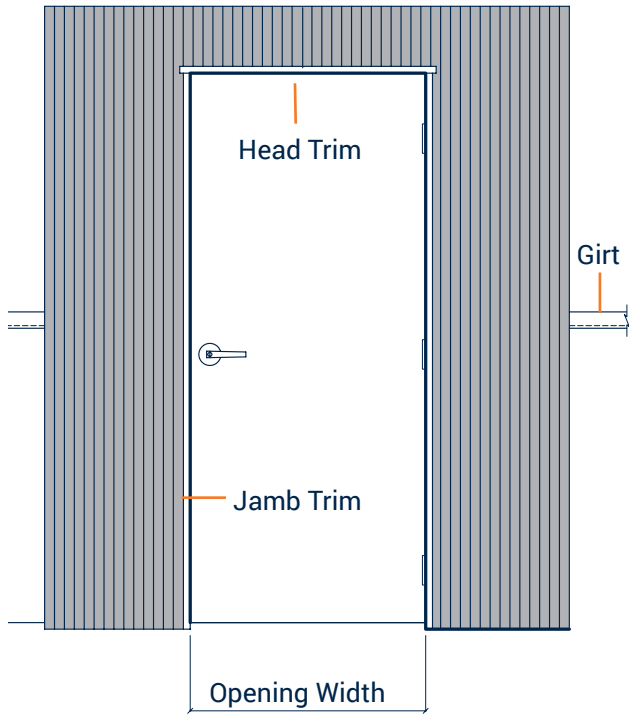

## Walk Door Options

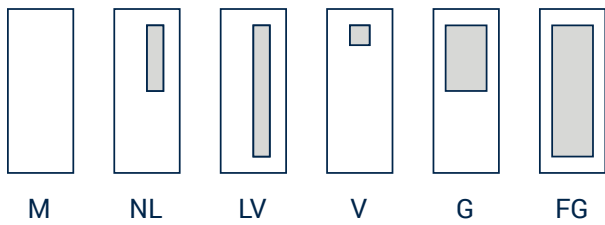

Window shown in gray.

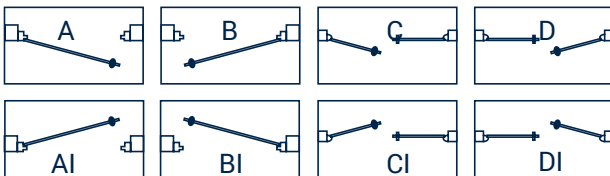

## Outside Of Building

## Windows

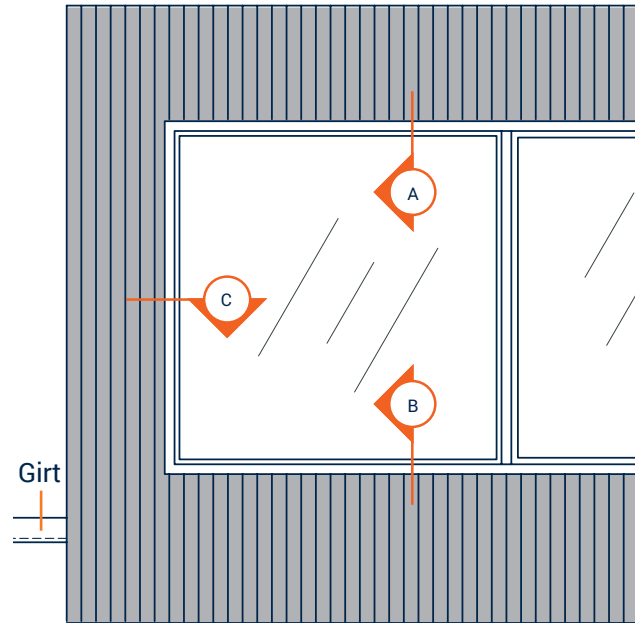

## Window Cross Section

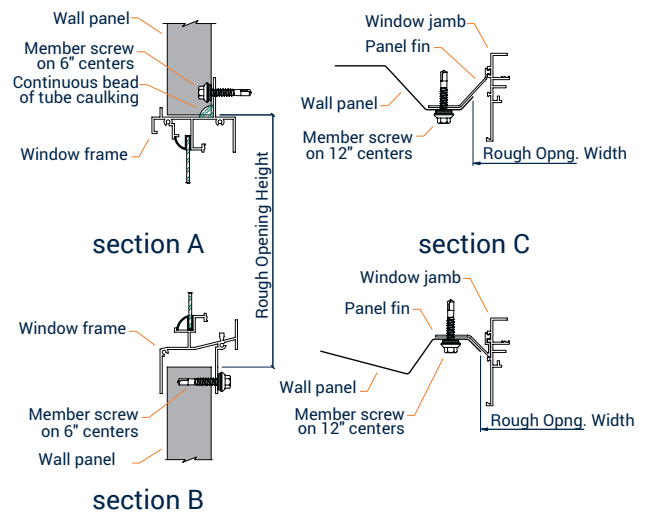

For more information and inspiration visit our website or give us a call.

**WHIRWLINDSTEEL.COM | (800) 324-9992**



Building  
Gallery



Metal Roofing, Walls,  
Trim & more



Self-Storage  
Solutions



Manufacturing  
Capabilities



Color  
Charts



Why Buy  
From Whirlwind



Quick  
Quote