

TEXAS DEPARTMENT OF INSURANCE

Engineering Services / MC 103-3A 333 Guadalupe Street P.O. Box 149104 Austin, Texas 78714-9104
Phone No. (512) 322-2212 Fax No. (512) 463-6693

PRODUCT EVALUATION RC-83

Effective January 1, 2005

*The following product has been evaluated for compliance with the wind loads specified in **International Residential Code (IRC)** and the **International Building Code (IBC)**. This product shall be subject to reevaluation 3 years after the effective date.*

This product evaluation is not an endorsement of this product or a recommendation that this product be used. The Texas Department of Insurance has not authorized the use of any information contained in the product evaluation for advertising, or other commercial or promotional purpose.

This product evaluation is intended for use by those individuals who are following the design wind load criteria in Chapter 3 of the IRC and Section 1609 of the IBC. The design loads determined for the building or structure shall not exceed the design load rating specified for the products shown in the limitations section of this product evaluation. This product evaluation does not relieve a Texas licensed engineer of his responsibilities as outlined in the Texas Insurance Code, the Texas Administrative Code, and the Texas Engineering Practice Act.

Super Span Panel (26 gauge and 29 gauge) metal roof panels manufactured by

Whirlwind Building Systems
P.O. Box 75280
Houston, Texas 77234-5280
(832) 553-4694

is acceptable in designated catastrophe areas along the Texas Gulf Coast when installed in accordance with the manufacturer's installation instructions and this product evaluation.

PRODUCT DESCRIPTION

Whirlwind Building Systems Super Span roof panels are cold-formed in 0.0170 inch (26 gauge) and 0.0134 inch (29 gauge) coated thickness from aluminum-zinc alloy Galvalume sheet steel by the hot dip process conforming to ASTM A792-83 AZ50. The panels conform to ASTM A446 Grade E, 80,000 psi minimum yield strength. The panels are manufactured in a 36-inch net coverage width with a 1 ¼ inch rib at 12 inches on center.

LIMITATIONS

Design Wind Pressures: For installations to nominal ½ inch plywood roof decks, design wind pressure limitations are specified in Table 1. For installations to continuous No. 2 SPF 2x4 purlins, design wind pressure limitations are specified in Table 2. For installations to continuous 16 gauge steel (hat) purlins, design wind pressure limitations are specified in Table 3.

Installation Over an Existing Roof Covering: Installation over an existing roof covering is limited to a maximum of one existing layer of composition shingles, wood shingles or shakes, built-up roofing, or roll roofing. If the roof panels are attached directly to the roof deck, then the existing roof deck shall not be less than nominal ½ inch wood structural panels. Note: Inspection of the existing roof deck must be made before installing the roof panels. The condition of the existing roof deck must be acceptable to receive the roof panels before the roof panel installation can proceed. For installations using purlins, the maximum allowable thickness of the existing roof covering is specified under Anchorage in the Installation Instructions section of this product evaluation report.

Roof Slope: The Super Span metal roof panels shall not be installed on roofs with a roof slope less than ½ :12.

INSTALLATION REQUIREMENTS

General Installation Requirements:

The installation of the panels shall be limited to extending one to two inches beyond the plane of the fascia board.

Panel Installation Requirements

Panels: Panels shall be attached in accordance with the Tables 1-3. Refer to Figure 1 and Figure 3 following the tables for illustrations of the screw patterns.

Table 1

Attachment of 26 and 29 gauge Super Span Roof Panel to minimum nominal $\frac{1}{2}$ inch wood structural panel roof decking:

Wind Pressure (psf)	Attachment of Roof Panel to Deck
-35	Screw Pattern #2 @ 4'-0" o.c.
-41	Screw Pattern #2 @ 3'-6" o.c.
-43	Screw Pattern #2 @ 3'-4" o.c.
-44	Screw Pattern #2 @ 3'-2" o.c.
-55	Screw Pattern #2 @ 2'-6" o.c.
-61	Screw Pattern #2 @ 2'-4" o.c.
-65	Screw Pattern #2 @ 2'-2" o.c.
-72	Screw Pattern #2 @ 2'-0" o.c.

Table 2

Attachment of 26 and 29 gauge Super Span Roof Panel to continuous 2x4 purlins, (No. 2 SPF). Purlins attached to roof trusses/rafters with Buildex™ Dec-King exterior wood screws. Maximum spacing of roof trusses/rafters – 2 feet o.c.

Wind Pressure (psf)	Attachment of Roof Panel to 2x4 Purlin	# Screws Per Purlin to Truss/Rafter
-40	Screw Pattern #1 @ 4'-0" oc	2 ea #8 x 3"
-44	Screw Pattern #1 @ 3'-6" oc	2 ea #8 x 3"
-55	Screw Pattern #1 @ 2'-8" oc	2 ea #8 x 3"
-59	Screw Pattern #1 @ 2'-8" oc	3 ea #8 x 3"
-64	Screw Pattern #1 @ 2'-6" oc	3 ea #8 x 3"
-65	Screw Pattern #1 @ 2'-4" oc	3 ea #8 x 3"
-72	Screw Pattern #1 @ 2'-2" oc	3 ea #8 x 3"

INSTALLATION REQUIREMENTS (continued)

Table 3

Attachment of 26 and 29 gauge Super Span Roof Panel to 16 gauge hat purlin.

Wind Pressure (psf)	Attachment of Roof Panel to 16 Gauge Hat Purlin	# Screws Per Purlin to Truss/Rafter
-34	Screw Pattern #1 @ 4'-6" oc	2 ea #8 x 2 1/2"
-36	Screw Pattern #1 @ 4'-0" oc	2 ea #8 x 2 1/2"
-42	Screw Pattern #1 @ 3'-6" oc	2 ea #8 x 2 1/2"
-44	Screw Pattern #1 @ 3'-4" oc	2 ea #8 x 2 1/2"
-55	Screw Pattern #1 @ 2'-8" oc	2 ea #8 x 2 1/2"
-61	Screw Pattern #1 @ 2'-4" oc	2 ea #8 x 2 1/2"
-65	Screw Pattern #1 @ 2'-2" oc	2 ea #8 x 2 1/2"
-72	Screw Pattern #1 @ 2'-0" oc	2 ea #8 x 2 1/2"

Underlayment: Minimum 15 pound resin-bound chopped-glass-fiber substrate (Elk Versashield™) by Elk Corporation, with 2 inch horizontal and 6 inch vertical joints. The Elk Versashield™ shall be fastened to the roof deck with corrosion resistant fasteners in accordance with the manufacturer's installation instructions. Fasteners shall be applied along the overlaps not farther apart than 36 inches on center. The underlayment shall be installed under the purlins if continuous wood purlins are used. The underlayment is optional if continuous purlins are installed over an existing roof covering.

Alternative Roof Underlayment: A minimum of one layer of No. 30 (Type II) asphalt felt shall be used. The underlayment used shall comply with one or more of the following: ASTM D 226, ASTM D 4869, or ASTM D 1970. The felt shall be installed with 4 inch side laps and 4 inch end laps. The felt shall be fastened to the roof deck with corrosion resistant fasteners in accordance with the manufacturer's installation instructions. Fasteners shall be applied along the overlaps not farther apart than 36 inches on center. The underlayment shall be installed under the purlins if continuous wood purlins are used. The underlayment is optional if continuous purlins are installed over an existing roof covering. Note: An optional radiant barrier may be installed beneath the panels in conjunction with the underlayment.

Anchorage:

To Roof Decking: The panels shall be fastened in accordance with Table 1 with #10-16x1 inch HWH Woodtite™ screws, manufactured by Atlas Bolt and Screw Company. If the panels are laid directly over an existing roof covering, then #10-16x1 1/2 inch HWH Woodtite™ screws are required. The fasteners shall be long enough to penetrate completely through the wood structural panels with a minimum exposure of 1/4 inch below the underside of the wood structural panels.

INSTALLATION REQUIREMENTS (continued)

To Continuous Purlins: The panels shall be fastened to the 2x4 wood purlins in accordance with Table 2 with #10-16 x 1 inch HWH Woodtite™ screws, manufactured by Atlas Bolt and Screw Company. The panels shall be fastened to the 16 gauge steel (hat) purlins in accordance with Table 3 using #12-14 HWH TCP 2 screws by Atlas Bolt and Screw Company. The purlins shall be spaced as specified in Tables 2-3. Each purlin shall be installed perpendicular to the slope of the roof and attached to the trusses/rafters (minimum SPF lumber) below with #8 Dec-King™ exterior wood screws, manufactured by ITW Buildex. The number of fasteners at each truss/rafter and the minimum length is specified in Table 2 for 2x4 purlins and Table 3 for 16 gauge steel (hat) purlins. If the purlins are installed over an existing roof covering, then the thickness of the existing roof covering shall not exceed $\frac{1}{4}$ inch if 2x4 purlins are used and 1 inch if 16 gauge steel (hat) purlins are used. If the thickness of the existing roof covering exceeds these limitations, then the existing roof covering must be removed.

Ridge Cap and Rake Trim: The ridge cap and the rake trim shall be attached to the panels with $\frac{1}{4}$ inch #14 x $\frac{7}{8}$ inch HWH self-drilling lap screws with #1 drill point as indicated in Figure 2 and in Figure 4. Elastic butyl tape (tape sealer) and $\frac{1}{4}$ inch #14 x $\frac{7}{8}$ inch self-drilling lap screws with #1 drill point and an EPDM integral washer, manufactured by Atlas Bolt and Screw Company, are required along the side laps spaced according to Figure 1 and Figure 3.

Alternative Fasteners: Substitution of equivalent fasteners shall meet the following requirements:

#10-16 HWH Woodtite™, manufactured by Atlas Bolt and Screw Company, sharp point screw with a $\frac{1}{2}$ inch Galvanized Head and bonded washer

Ultimate withdrawal (pullout) \geq 312 lbs. in $\frac{1}{2}$ inch wood structural panels

Ultimate withdrawal (pullout) \geq 804 lbs. with 1 inch penetration of a No. 2 SPF 2x4

Ultimate pullover through 26 ga. steel \geq 500 lbs.

Ultimate pullover through 29 ga. steel \geq 455 lbs.

#12-14 TCP2 self-drilling screw with #2 drill point Oxyseal II™ long life coating.

Ultimate withdrawal (pullout) \geq 851 lbs. in 16 ga steel.

Ultimate pullover through 26 ga. steel \geq 577 lbs.

Ultimate pullover through 29 ga. steel \geq 397 lbs.

#8-15 Bugle Head Dec-King™ exterior wood screw with Climacoat™

2 $\frac{1}{2}$ inch ultimate withdrawal (pullout) \geq 630 lbs. with 1 $\frac{1}{4}$ inch penetration of stud grade SYP

3" ultimate withdrawal (pullout) \geq 645 lbs. with 1 $\frac{1}{4}$ inch penetration of stud grade SYP

Corrosion resistance by ASTM B 117 for 500 hrs. (5% or less red rust)

$\frac{1}{4}$ inch #14 x $\frac{7}{8}$ inch TCPI with Oxyseal II™ long life coating

Ultimate withdrawal (pullout) in 26 ga. steel \geq 365 lbs.

Ultimate withdrawal (pullout) in 29 ga. steel \geq 332 lbs.

Ultimate pullover through 26 ga. steel \geq 536 lbs. ($\frac{5}{8}$ inch diameter bonded washer)

Ultimate pullover through 29 ga. steel \geq 382 lbs.

Note: The manufacturer's installation instructions shall be on the job site during the installation. All fasteners shall be corrosion resistant as specified in the International Residential Code (IRC) and the International Building Code (IBC).

SUPERSPAN PANEL TYPICAL DETAILS

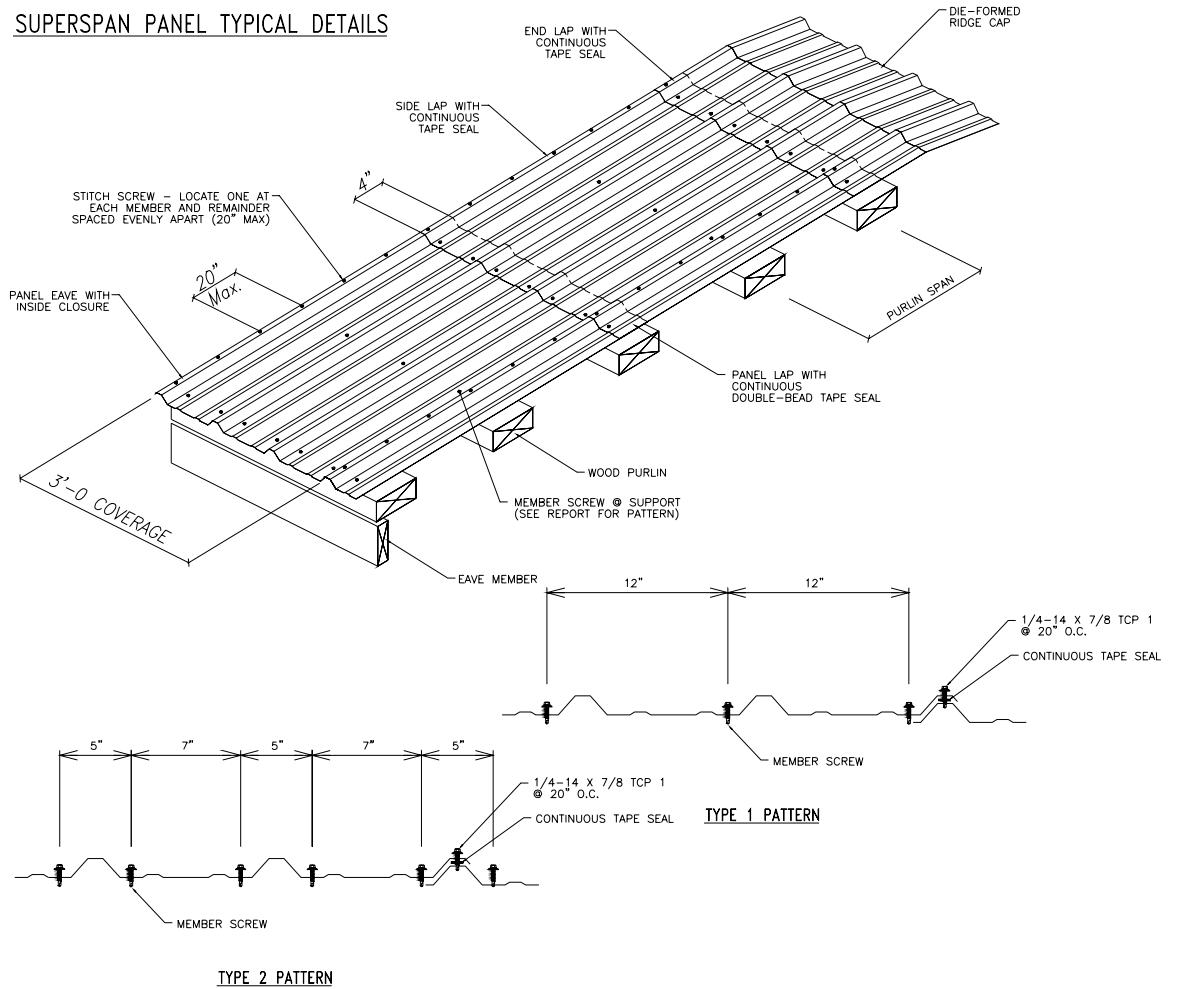

Figure 1: Super Span - Panel Installation Over 2x4 Purlins

SUPERSPAN PANEL TYPICAL DETAILS

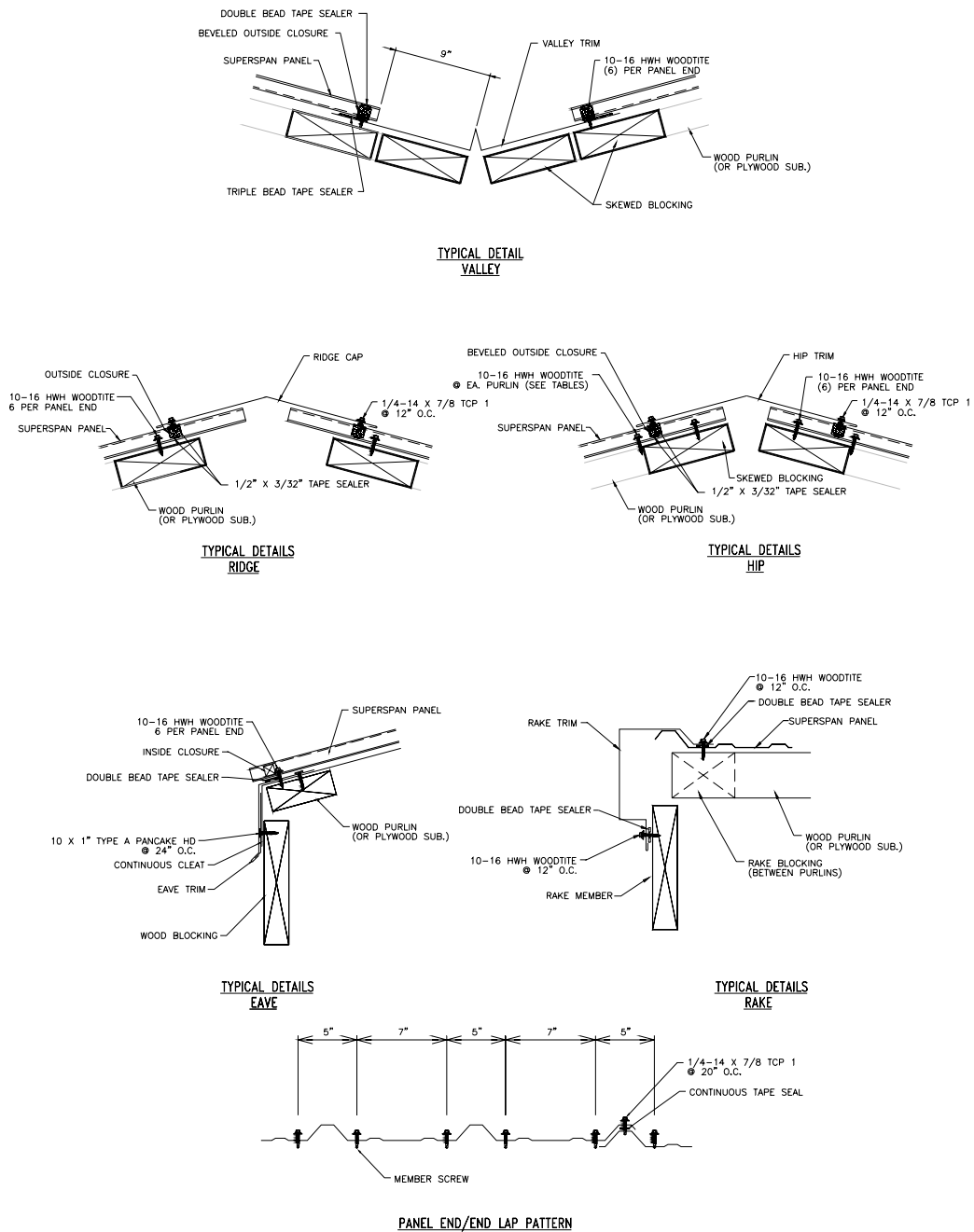

Figure 2: Super Span - Panel Installation Over 2x4 Purlins - Details

SUPERSPAN PANEL TYPICAL DETAILS

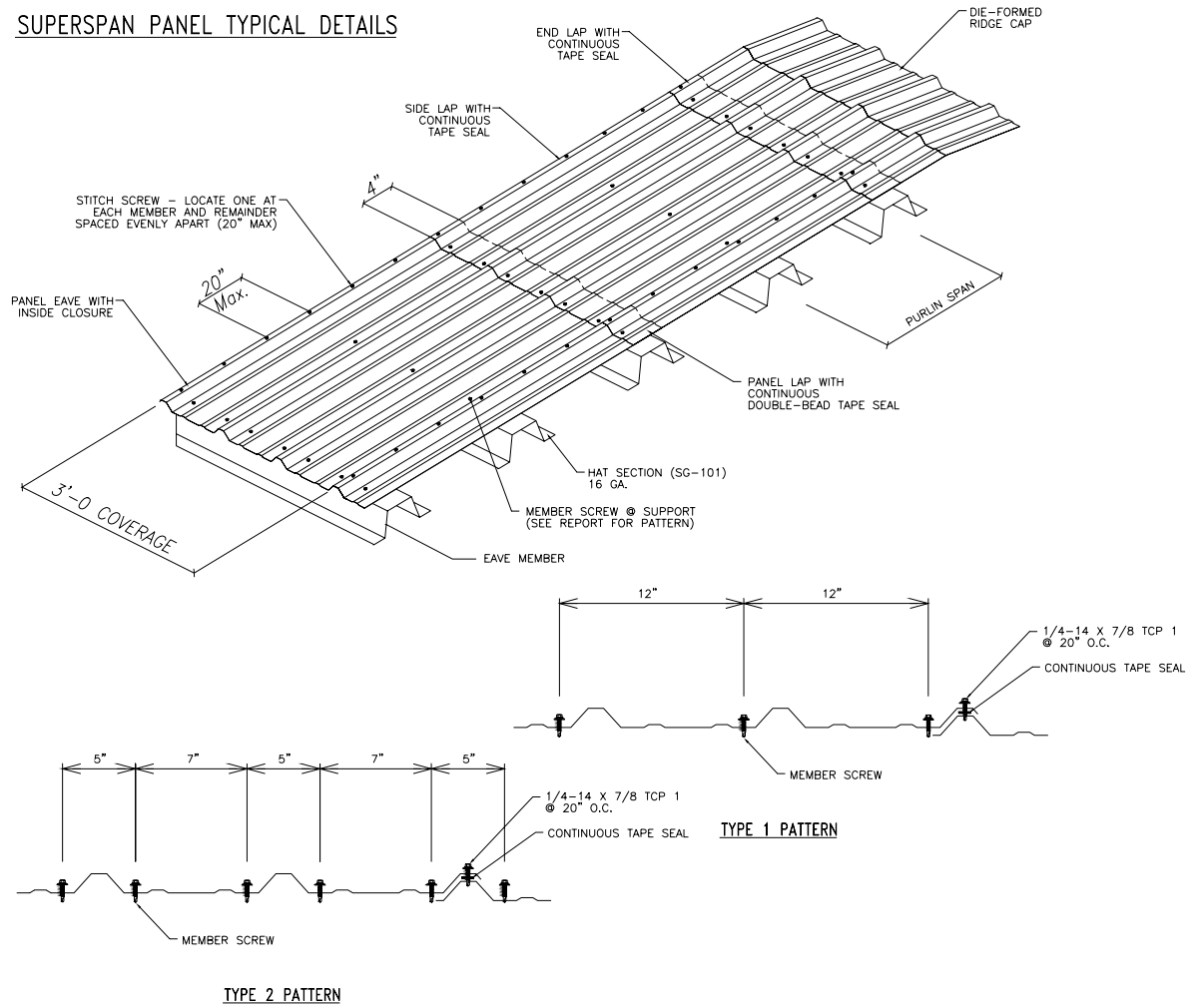

Figure 3: Super Span - Panel Installation Over 16 Gauge (Hat) Purlins

SUPERSPAN PANEL TYPICAL DETAILS

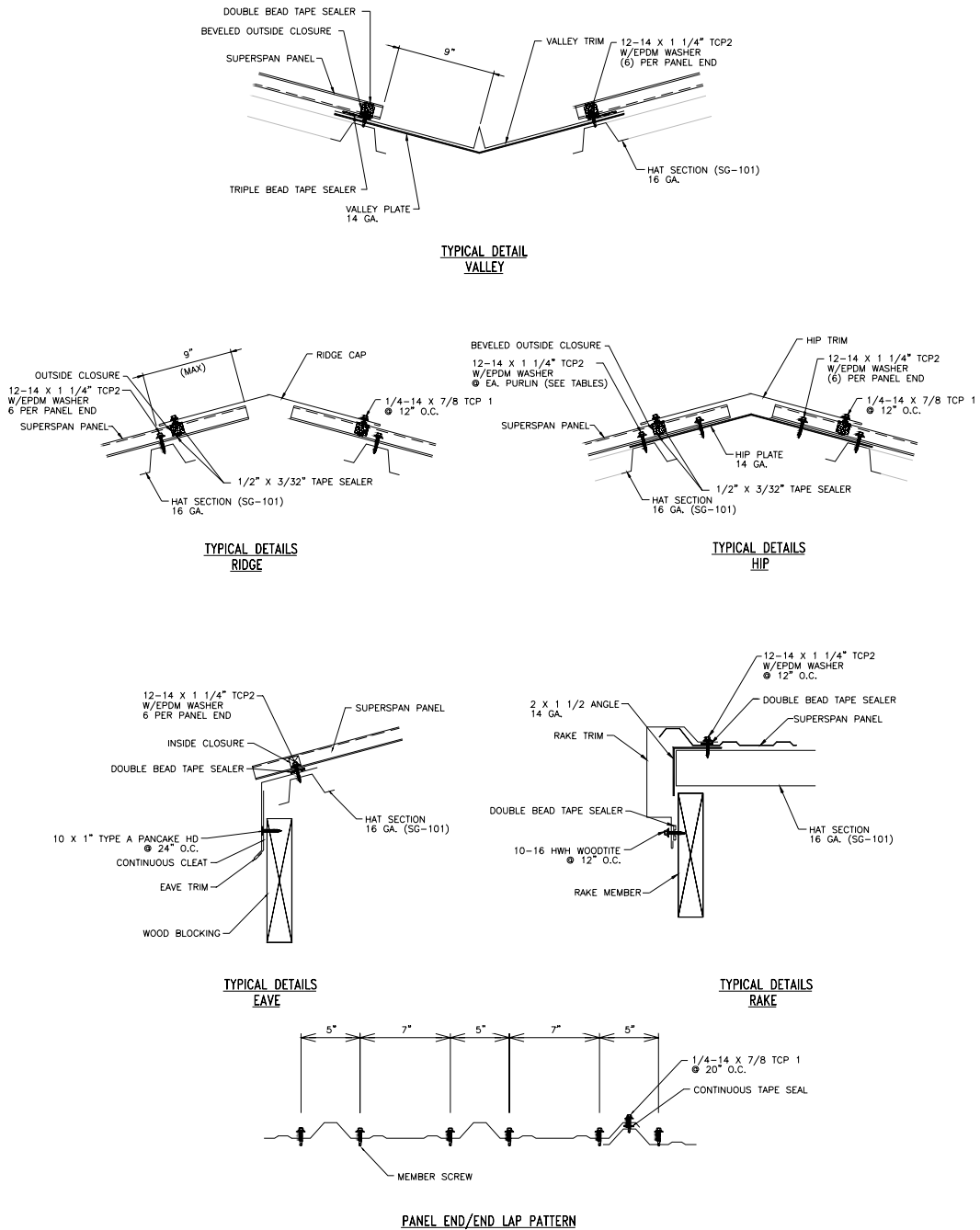

Figure 4: Super Span - Panel Installation Over 16 Gauge (Hat) Purlins - Details