



**STEEL BUILDINGS INC.**

*Shadow Wall-18*

---

**TECHNICAL/ERECTION INFORMATION**

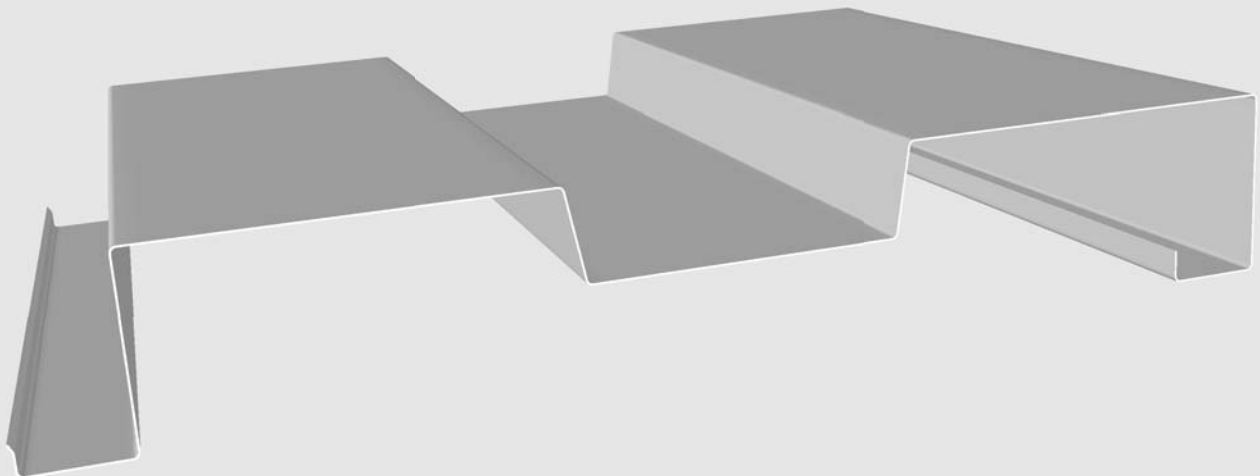

# IMPORTANT NOTICE

**READ THIS MANUAL COMPLETELY PRIOR TO BEGINNING THE INSTALLATION OF THE SHADOW WALL PANEL.**

**IF THERE IS A CONFLICT BETWEEN PROJECT ERECTION DRAWINGS PROVIDED OR APPROVED BY WHIRLWIND BUILDING SYSTEMS AND DETAILS IN THIS MANUAL, PROJECT ERECTION DRAWINGS WILL TAKE PRECEDENCE.**

©Copyright Whirlwind Steel Buildings, Inc. All Rights Reserved.

Descriptions and specifications contained herein were in effect at the time this publication was approved for printing. In a continuing effort to refine and improve products, Whirlwind reserves the right to discontinue products at any time or change specifications and/or designs without incurring obligation. **To insure you have the latest information available, please inquire or visit our Web Site at <http://www.whirlwindsteel.com>.** Application details in this manual may not be appropriate for all environmental conditions, building designs, or panel profiles. Projects should be engineered to conform to applicable building codes, regulations, and accepted industry practices. Insulation is not shown in these details for clarity.



## *Shadow Wall-18*

## TABLE OF CONTENTS

GENERAL NOTES AND INFORMATION .....	SW-2
PANEL PERFORMANCE WARNINGS .....	SW-3
PANEL SAFETY WARNINGS .....	SW-4
GENERAL ERECTION NOTES .....	SW-5
TYPICAL PANEL ATTACHMENT .....	SW-6
ALTERNATE PANEL ATTACHMENT .....	SW-7
OUTSIDE CORNER DETAIL (HIGH) .....	SW-8
OUTSIDE CORNER DETAIL (LOW) .....	SW-9
INSIDE CORNER DETAIL (HIGH) .....	SW-10
INSIDE CORNER DETAIL (LOW) .....	SW-11
JAMB DETAILS .....	SW-12
FRAMED OPENING DETAILS .....	SW-13
MISCELLANEOUS DETAILS .....	SW-14
BASE ANGLE DETAILS .....	SW-15
BASE GIRT DETAILS .....	SW-16
BASE CHANNEL DETAILS .....	SW-17
SUPER SPAN EAVE DETAILS .....	SW-18
SUPER SEAM EAVE DETAILS .....	SW-19
WEATHER PANEL EAVE DETAILS .....	SW-20
RAKE DETAILS .....	SW-21



## Shadow Wall-18

### GENERAL NOTES AND INFORMATION

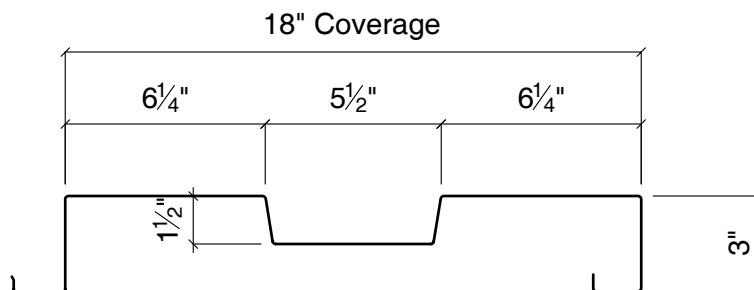

SHADOW WALL-18™

1. Shadow Wall-18 is a concealed fastener wall panel that provides an attractive shadow effect on the walls.
2. The Shadow Wall-18 system is based on an 18" module, and a panel layout should be provided for each wall to ensure that the framed openings start and finish in the "high" of the panel. Although this is not absolutely necessary, it will provide a much cleaner appearance, as well as being easier to erect.
3. All dimensions should be verified by field measurement prior to ordering the panels.
4. The Shadow Wall-18 panel is attached to the structural members using a Fab-Lok® fastener. This fastener is installed from inside the building through a pre-drilled 5/16" hole. The structural members must be properly aligned to prevent oil-canning in the panels.
5. The maximum length of this panel is 40'-0". Panels may be spliced using Whirlwind's splice trim for continuous runs over 40'-0".
6. Because of the difficulties in erecting, Whirlwind recommends the use of batt insulation in lieu of blanket insulation.
7. The ACCESSORIES section of the catalog contain the various types and sizes of member and stitch screws that can be used with this panel. Refer to your salesperson if you need any additional information or assistance when selecting these fasteners.



## *Shadow Wall-18*

### **PANEL PERFORMANCE WARNINGS**

The building panels are manufactured to the highest quality standards, offering long-term durability and performance. To assure optimum panel performance, special precautions must be taken while the panels are in a packaged state. Please take notice of the followings WARNINGS to insure that your panels are properly protected prior to installation and installed properly. Failure to follow these recommendations could void any panel warranty.

#### **A. JOBSITE STORAGE**

1. All building panels are extremely vulnerable to finish deterioration from moisture when in the nested, packaged condition. Long term storage of these panels (over 30 days) in the nested, packaged condition can be detrimental and may void the panel finish warranty. Erect panels immediately upon receipt for best results.
2. The wrapping used in the packaging is designed to aid in the resistance of wind blown moisture during transit and job site storage prior to panel installation. All packages of panels should be inspected for the presence of moisture upon arrival. If moisture is present, panels must be separated and allowed to dry completely prior to restacking. Under no circumstances should panels be allowed to remain nested in a wet or damp state.
3. Moisture can form between dry panels from temperature changes alone. This can happen even when kept undercover, out of the elements, and especially in winter. It is very important to install all panels as soon as possible.
4. Job site storage is the responsibility of the buyer and should always include tarping and the elevation of one end of every panel package to aid in the draining of any moisture that may accumulate between panels. Panels should always be stored above rising water levels.
5. Panels with evidence of water stain, paint blistering or other defects attributed to improper or long term field storage will not be eligible for claim.

#### **B. INSTALLATION**

1. All metal shavings or iron fines created during the erection process by drilling holes, cutting, or sawing must be swept off of the roof and wall panels daily. Failure to do so may cause permanent rust stains on the painted surface. Claims will not be accepted for this problem.
2. Cutting of panels or trim with circular saws is strongly discouraged. The fine metal particles created are hot and will embed themselves into any painted surface they contact. Removal of all of these particles is nearly impossible and will cause rust spots on the painted surfaces. This problem occurs most when cutting endwall panels to slope or cutting around wall openings. Claims will not be accepted for this problem.
3. All panels should be installed in a manner that the bottom cut edge of the panels is at least 1/4" above any direct contact with the concrete recess. The lime in the concrete will react with the aluminum in the GALVALUME® coating and cause coating failure and edge rust. Claims will not be accepted for this problem.
4. All panels installed with blanket insulation should follow this WARNING. Never cut the insulation off even with the edge of the panels as this will cause "wicking" of moisture and panel rust. Always fold back the insulation, with facing outward, at least 1" away from the panel edge.
5. Some panels are furnished with a protective, peel-off film. This film must be removed prior to field installation. Do not expose the panels to sunlight without immediate film removal. Film must be removed from non-exposed panels within six months after film application or irreparable damage will occur to the panel surface. Claims will not be accepted for this problem.



**WHIRLWIND STEEL BUILDINGS INC.**  
8234 Hansen Rd. | Houston, TX 77075 | (Phone) 713.946.7140 | (US Wats) 800.324.9992

## *Shadow Wall-18*

### **PANEL SAFETY WARNINGS**

1. These panels should be installed by a qualified professional that is knowledgeable with the proper installation of metal building panels and the safety precautions required.
2. Never install panels without wearing a tied-off safety harness and/or using a safety net as required by OSHA.
3. Unpainted secondary panels may have protective oil and/or metal working lubricant residues on their surfaces. Painted panels are coated with a wax to protect the painted surface during shipment. All panels should be viewed as extremely slippery, even if dry.
4. Never install or walk on wet building panels. Panels become extremely slippery when wet and could cause slippage or injury.
5. Take extreme care when walking on panels early in the morning as morning dew could be present and cause panels to be extremely slippery.
6. Never install panels in inclement weather (i.e. ice, snow, rain, lightning, etc.) as slippage or injury could occur.
7. All sloped roofs are dangerous. Be extremely careful when working on any sloped roof to avoid slipping or loss of balance.
8. Never install panels on windy days. Installers may be subject to injury if wind gusts cause them to lose their balance while carrying panels.
9. Be extremely careful installing panels (or any other steel or metal items) near electrical lines as these panels or items will conduct electricity and could cause electrocution.
10. Never walk on the top panel of an unsecured package of panels. The top panel will slide easily and may cause a fall and/or injury.
11. Never leave a bundle of panels unsecured on the sloped roof of a structure. The panels could slide off the roof like a "deck-of-cards" causing injury to those on the ground.
12. Always handle panels with care as all panel edges are sharp and can easily cause injury. Whenever possible, use gloves when handling.
13. **DO NOT WALK ON LIGHT TRANSMITTING PANELS!** Light transmitting panels must not be used for foot traffic nor should they support the undistributed weight of any individual. Roofing ladders or 1" x 12" planks must be used during installation, maintenance, or repair problems.



**WHIRLWIND STEEL BUILDINGS INC.**  
8234 Hansen Rd. | Houston, TX 77075 | (Phone) 713.946.7140 | (US Wats) 800.324.9992

## *Shadow Wall-18*

### GENERAL ERECTION NOTES

1. Make sure the building or structure is square and plumb before installing the sheeting and trim.
2. The drilling of holes in the roof panels by either the screws or a screw gun will leave metal shavings on the roof. These shavings must be swept from the roof each day to prevent surface rust. This rust may damage the panel finish and will void the panel warranty.
3. Do not cut any panels with a circular saw after they have been installed. The hot shavings may collect on the panel surface and damage the panel finish, voiding the panel warranty.
4. Stitch screws are used for panel to panel and/or panel to trim attachments. Member screws are used to attach panels and/or trim to the structurals. Either of these fasteners may be self-drilling or self-tapping, depending on which was ordered.
5. Some panels may require bevel cuts (i.e. hip condition, valley condition, endwall panels, etc.). All bevel cuts will be done in the field by the installer.
6. Rake trim, eave trim and gutter lap 2". All other trims lap 1".
7. Make sure all tape sealants and caulking are installed without any gaps or breaks.
8. The following pages show examples of standard conditions. Refer to your salesperson for assistance with non-standard conditions.



# Shadow Wall-18

## TYPICAL PANEL ATTACHMENT

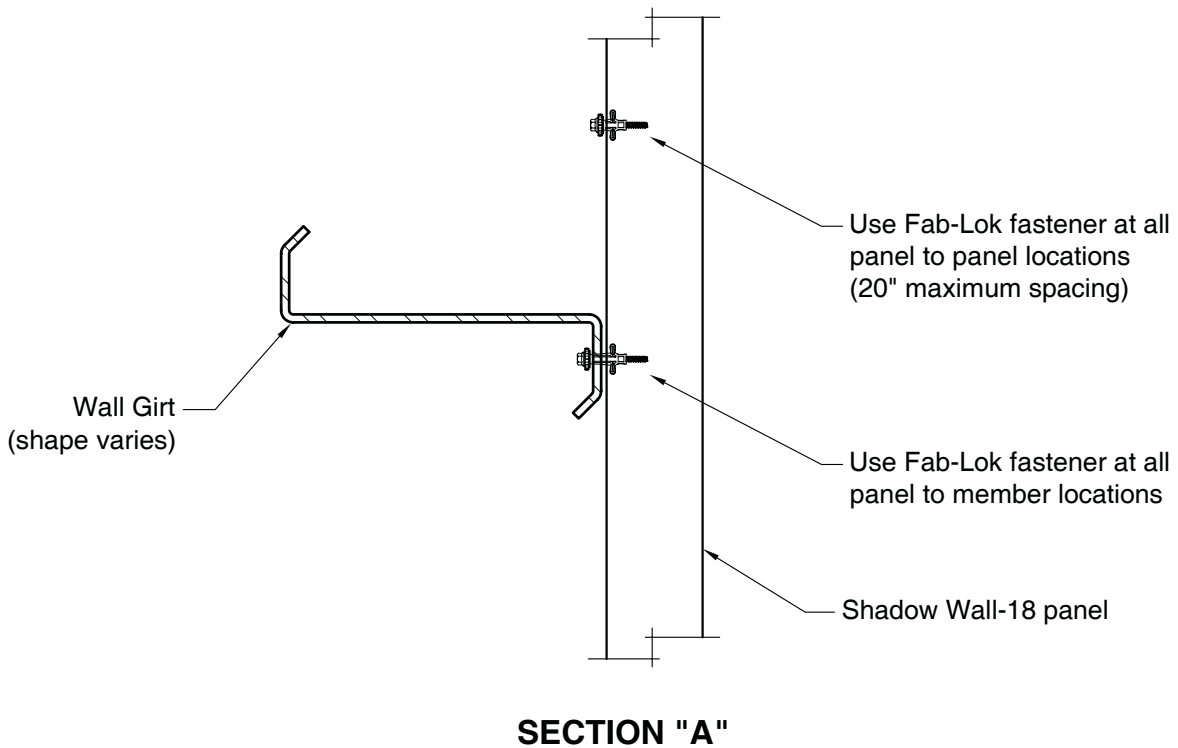
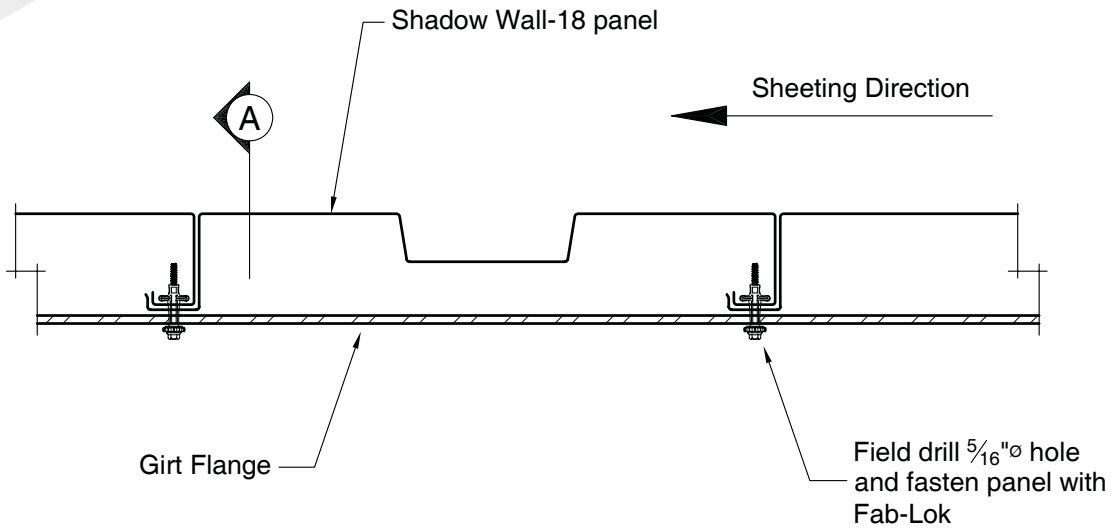

NOTE: Fab-Loks are installed from the inside of the building.



# Shadow Wall-18

## ALTERNATE PANEL ATTACHMENT

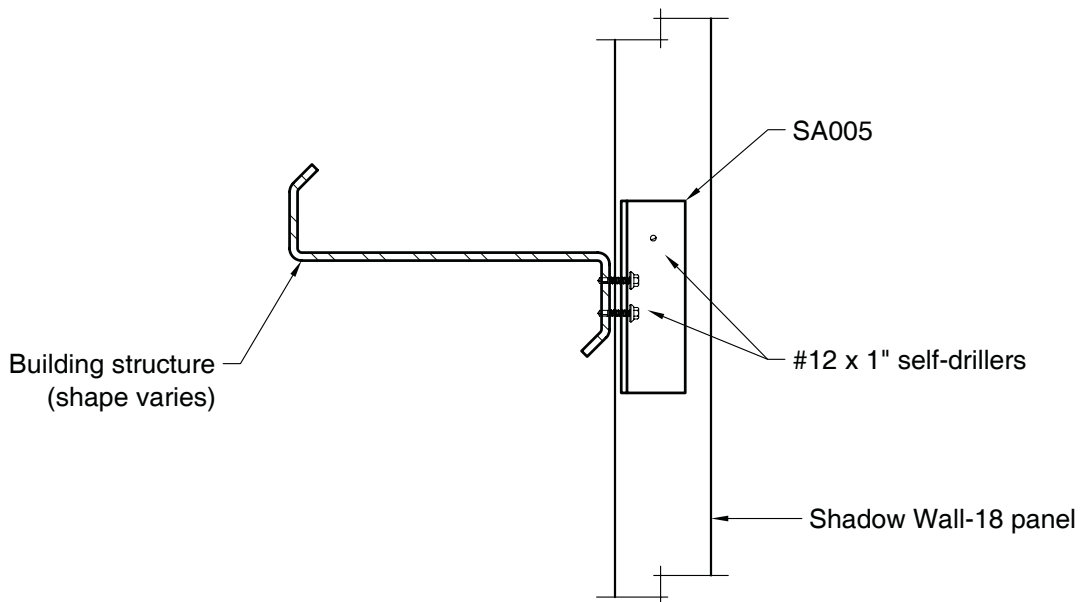
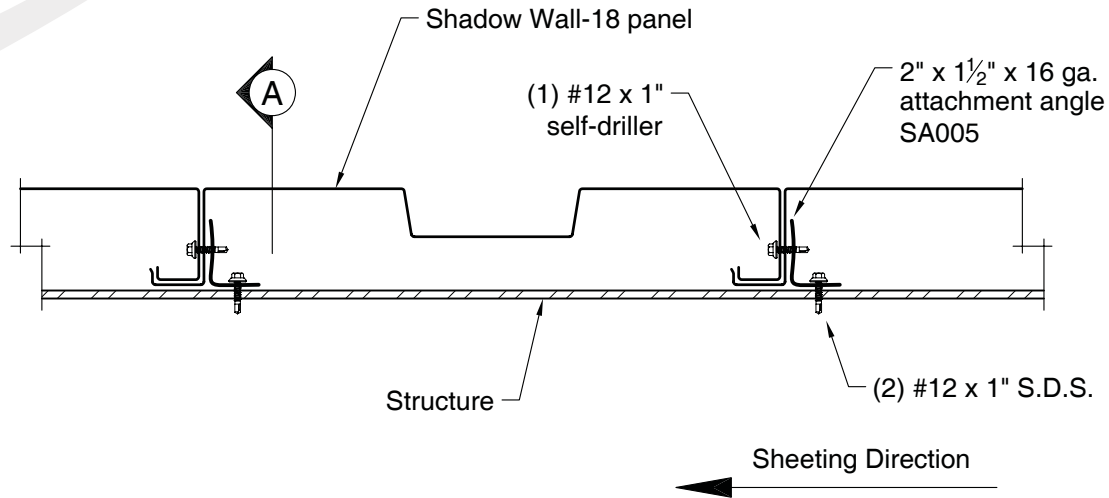

### SECTION "A"

Notes:

1. A 2" x 1½" x 16 ga. continuous starter angle (SA005) is used at the starting corner of each wall. Make sure this angle is installed plumb since it controls the 18" module for the entire wall.
2. 2" x 1½" x 16 ga. x 6" long angle clips are installed on 18" centers with #12 x 1" self-drilling fasteners as shown.
3. It is critical that the clip lines are installed plumb to control the 18" modules.
4. For clarity, insulation is not shown.



# Shadow Wall-18

## OUTSIDE CORNER DETAIL (HIGH)

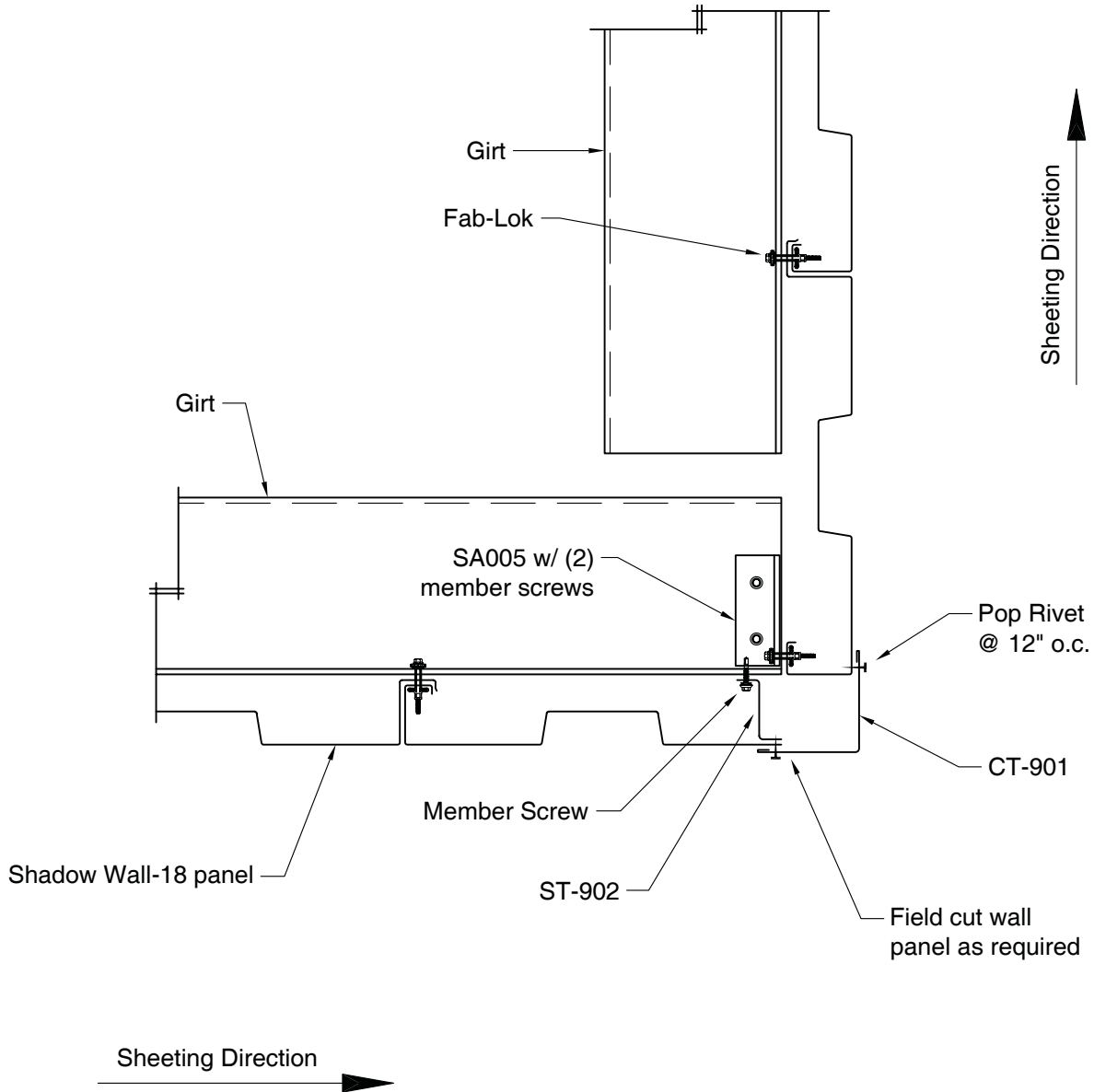



# Shadow Wall-18

## OUTSIDE CORNER DETAIL (LOW)

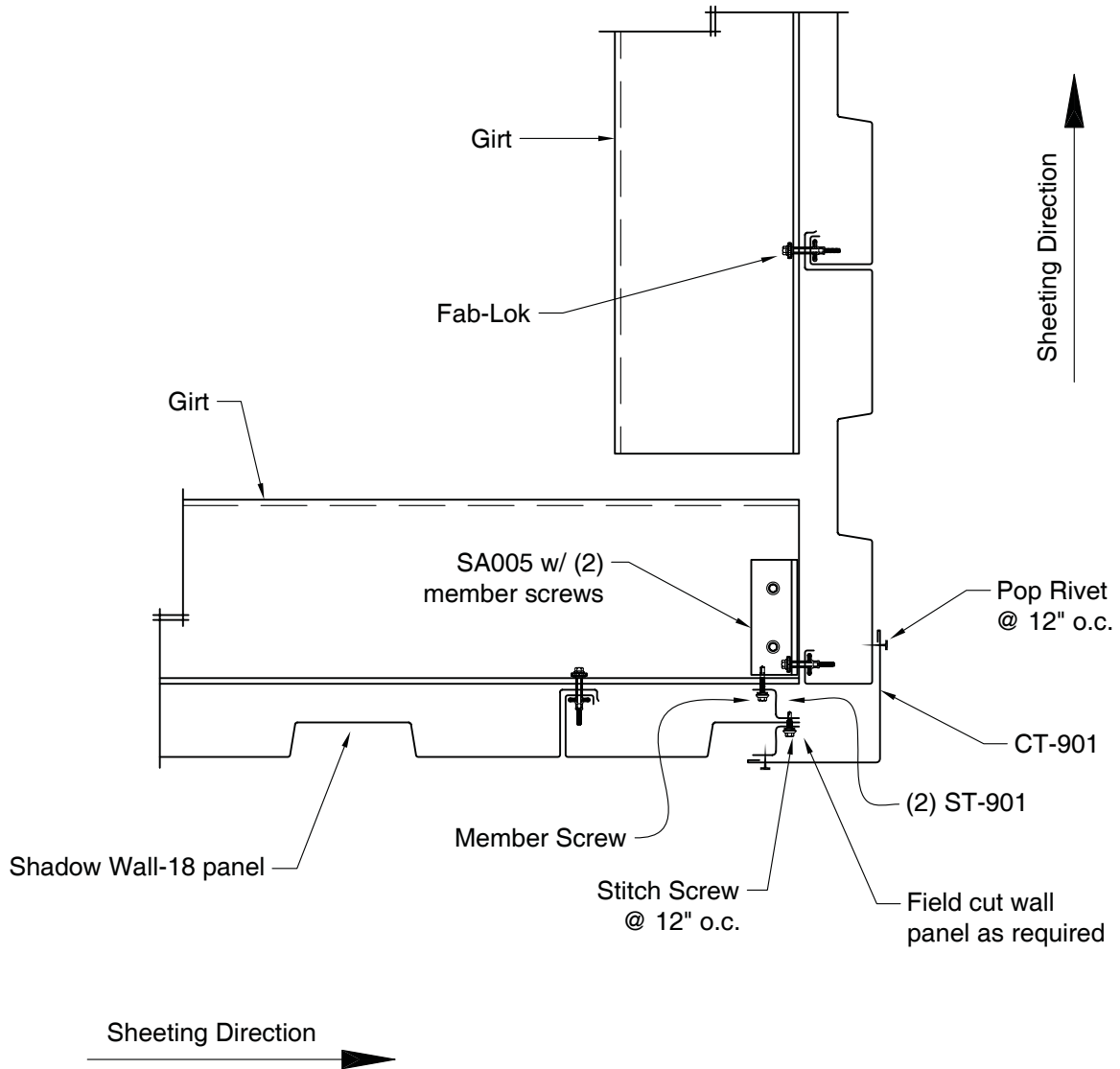



# Shadow Wall-18

## INSIDE CORNER DETAIL (HIGH)

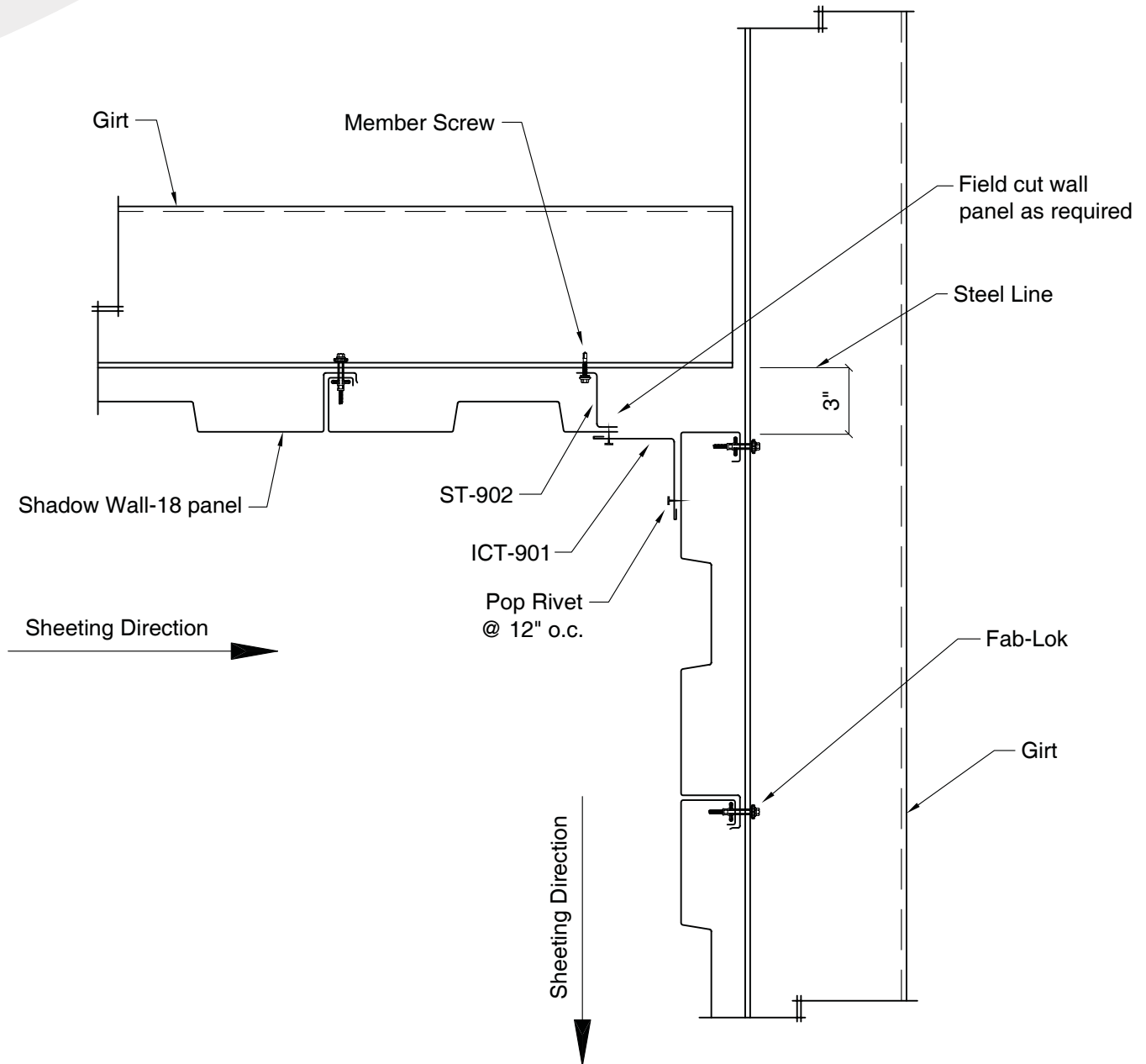

NOTE: When sheeting away from an inside corner, start sheeting 3" away from the steel line.



**Shadow Wall-18**

**INSIDE CORNER DETAIL (LOW)**

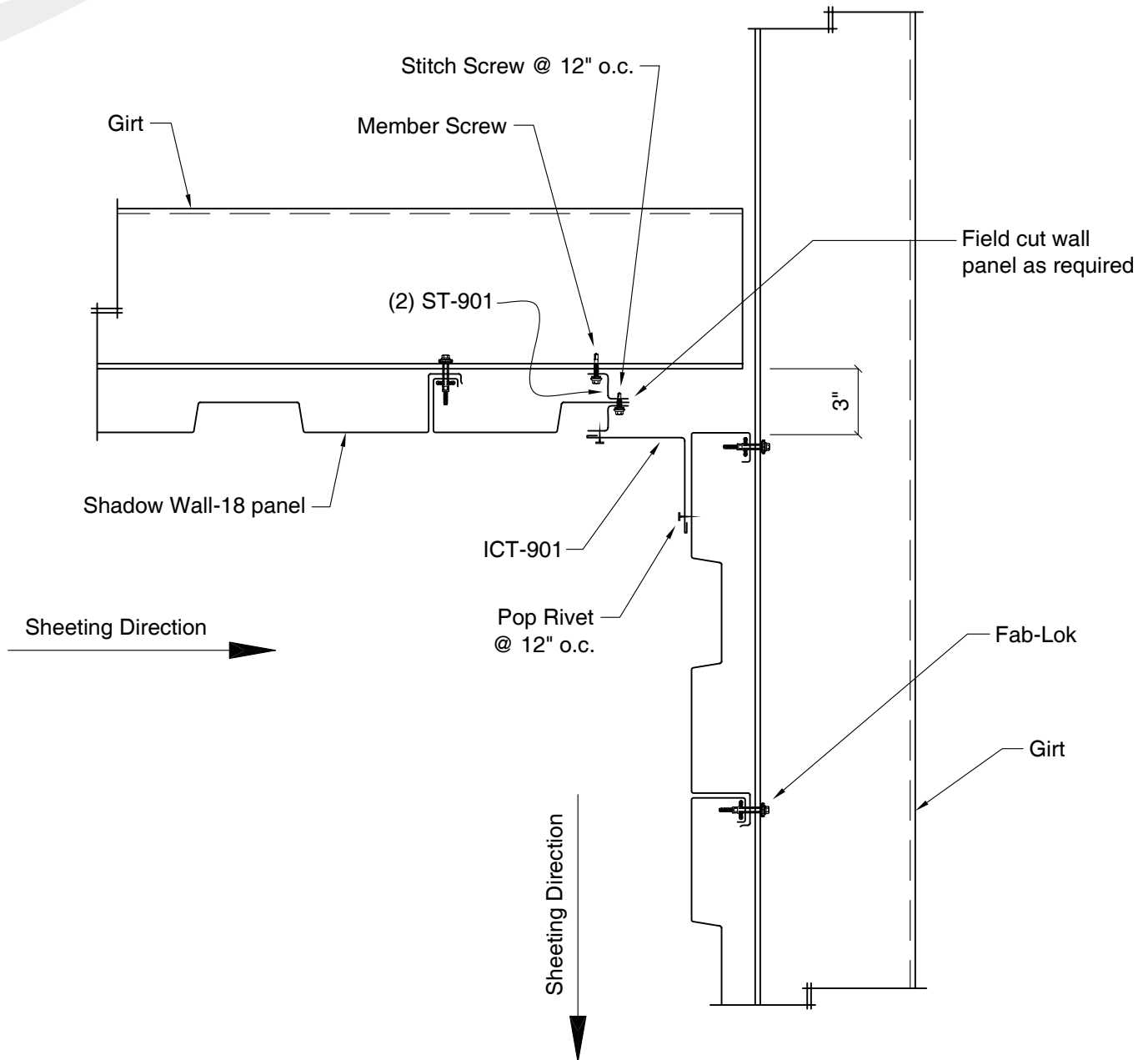

NOTE: When sheeting away from an inside corner, start sheeting 3" away from the steel line.



# Shadow Wall-18

## JAMB DETAILS

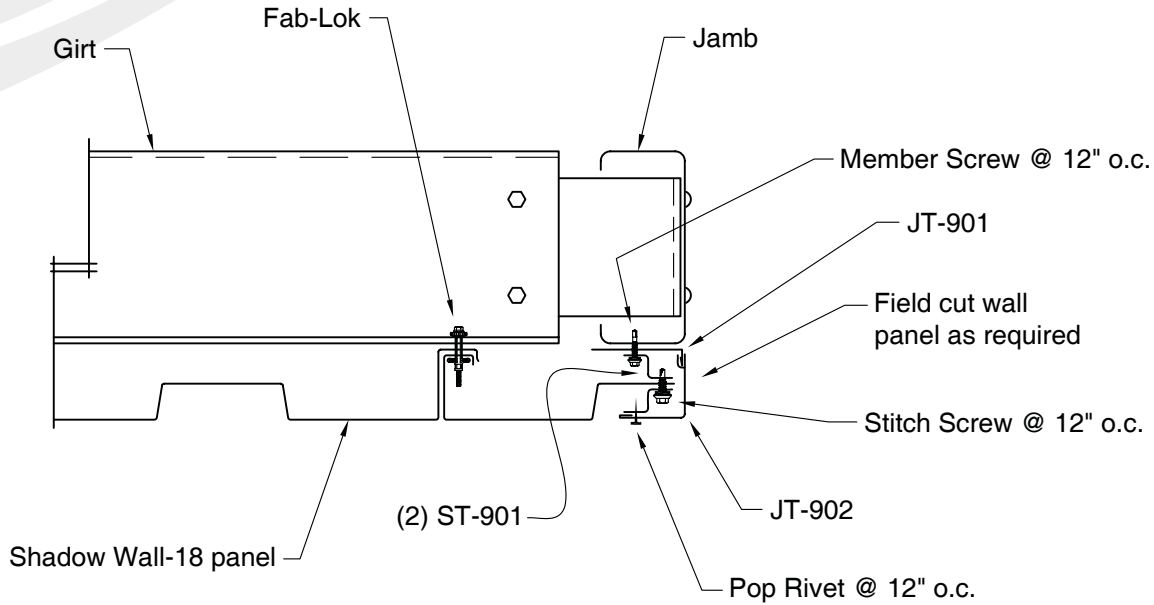

**Finish In Low**

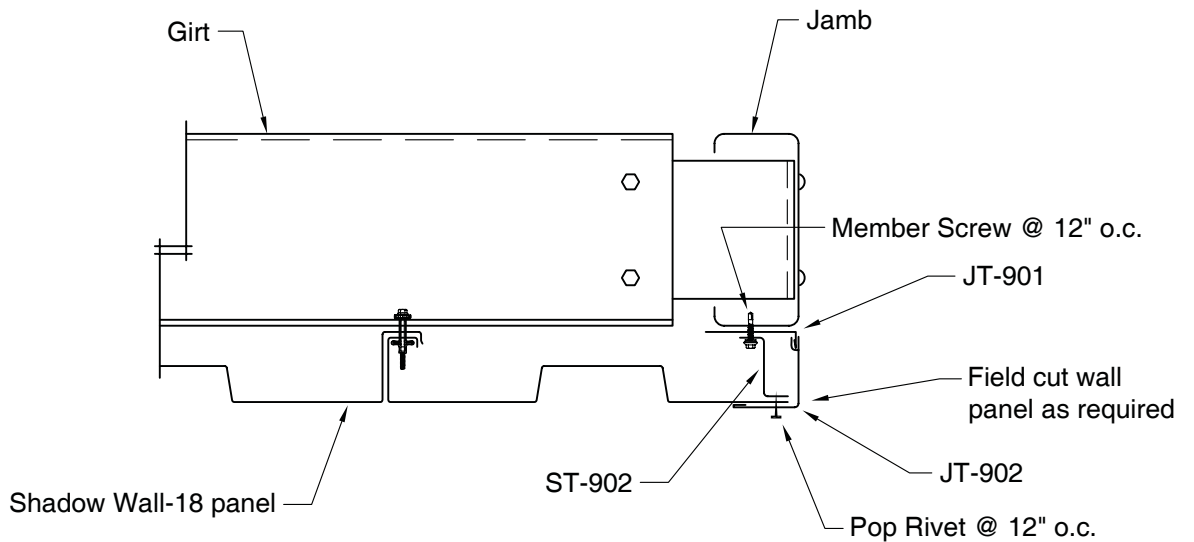

**Finish In High**



# Shadow Wall-18

## FRAMED OPENING DETAILS

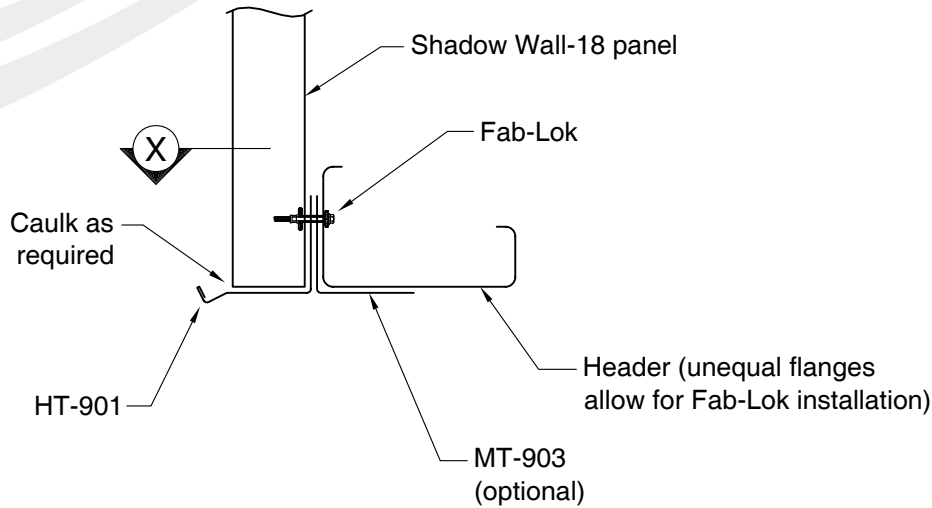

**Section At Head**

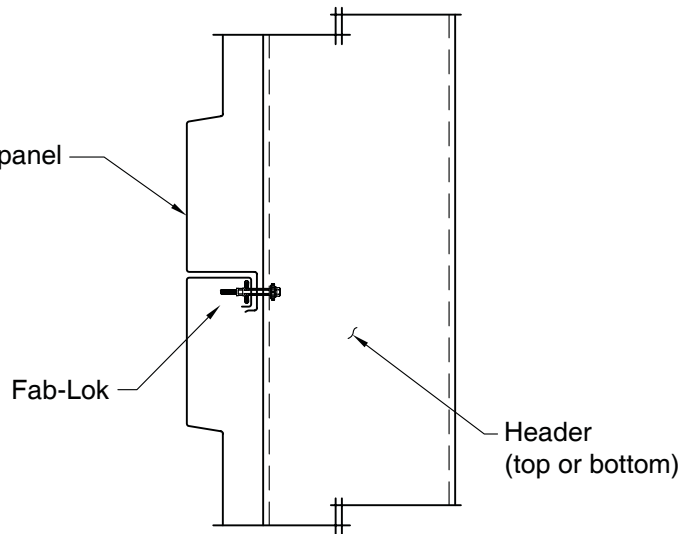

**Section "X"**

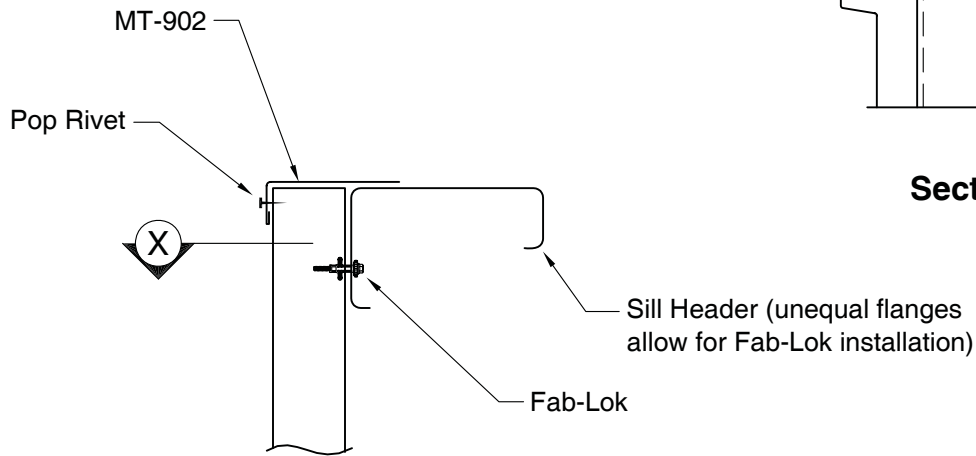

**Section At Sill**



# Shadow Wall-18

## MISCELLANEOUS DETAILS

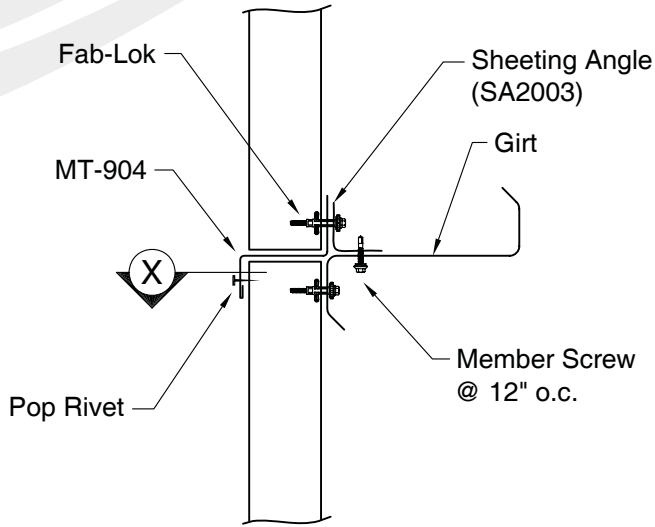

**Section At Wall Splice**

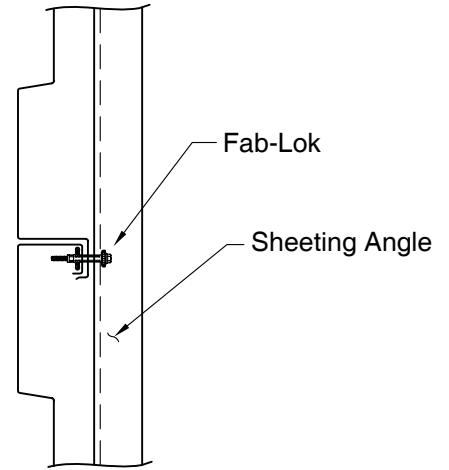

**Section "X"**

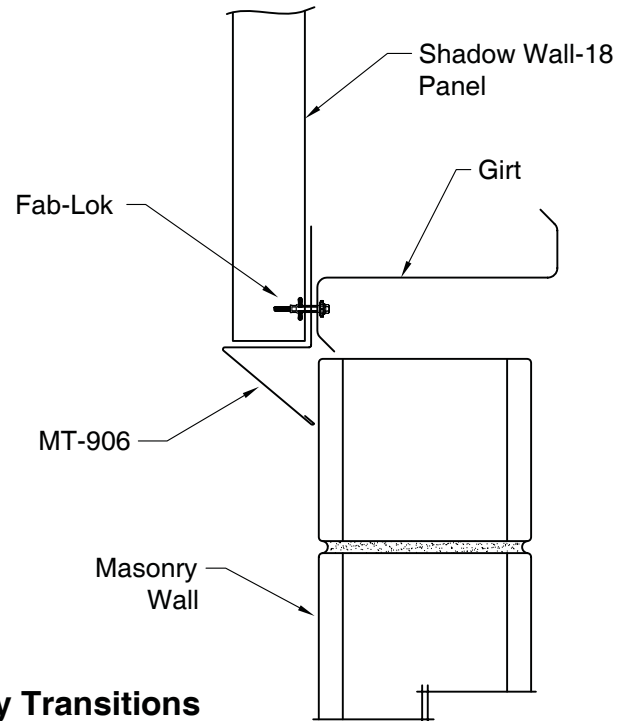
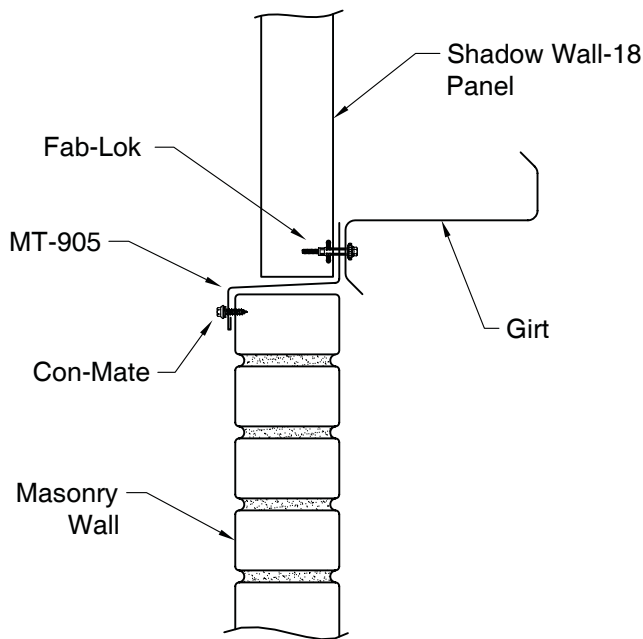

**Sections At Masonry Transitions**



# Shadow Wall-18

## BASE ANGLE DETAILS

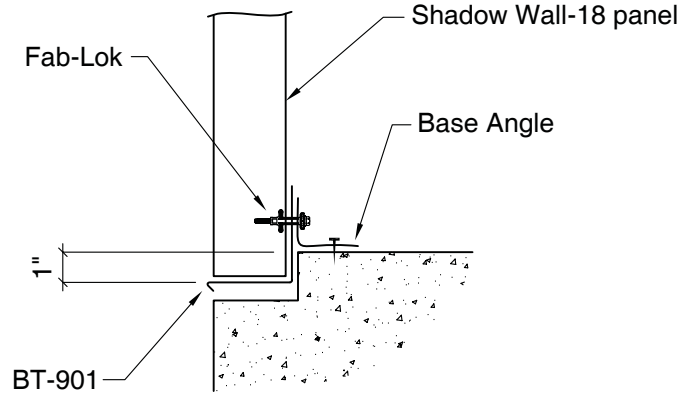

**With Sheeting Recess**

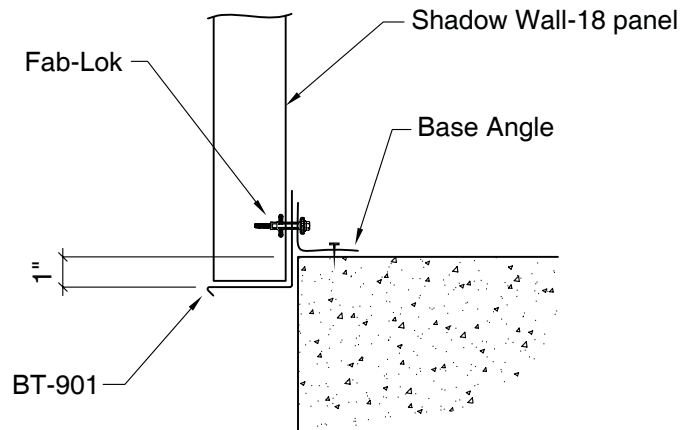

**Without Sheeting Recess**



# Shadow Wall-18

## BASE GIRT DETAILS

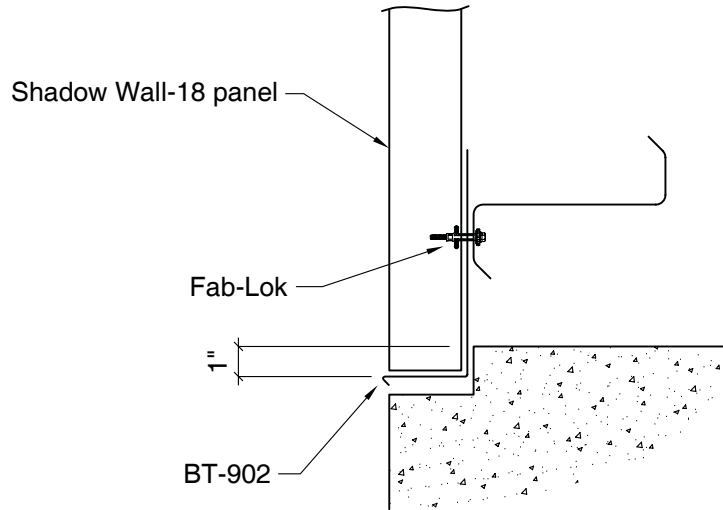

**With Sheeting Recess**

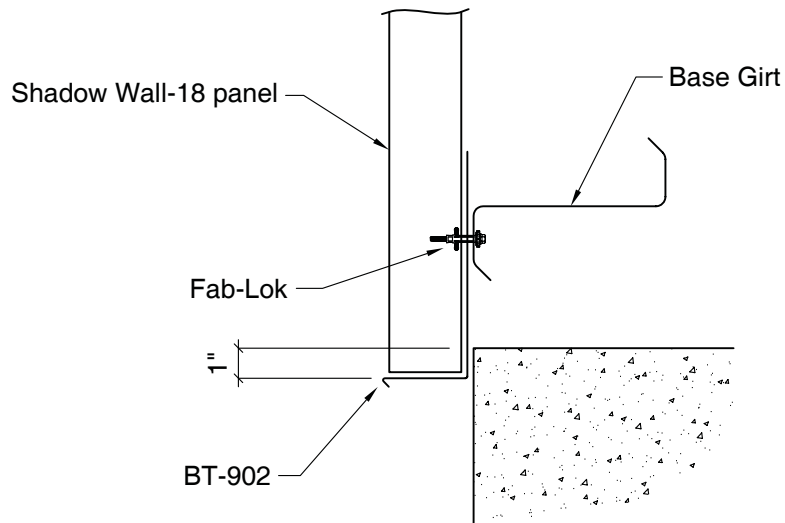

**Without Sheeting Recess**



# Shadow Wall-18

## BASE CHANNEL DETAILS

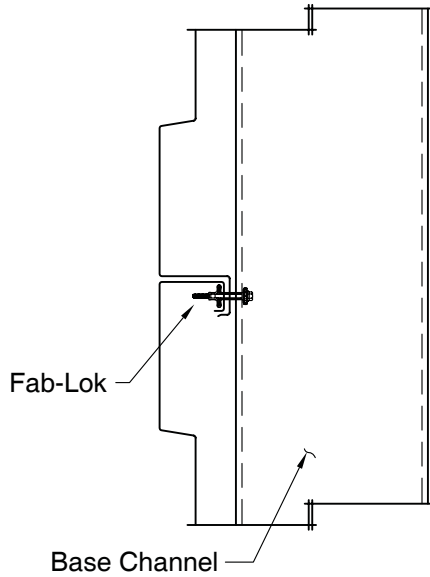

**Section "X"**

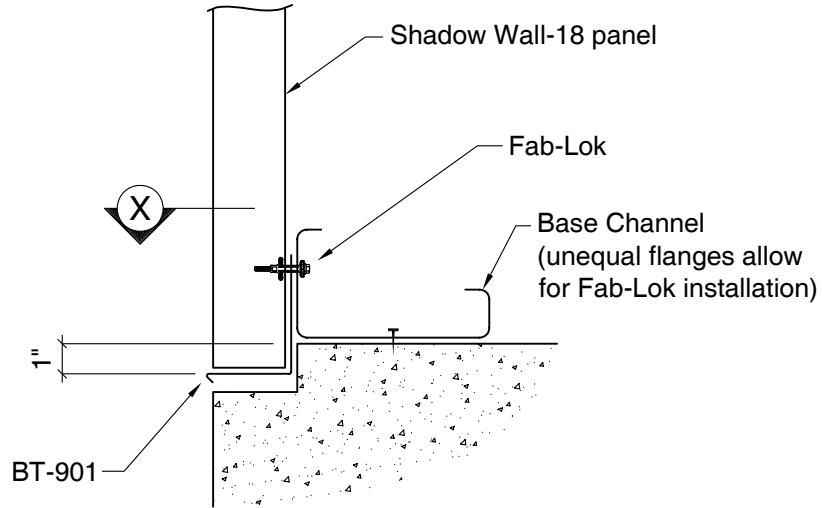

**With Sheeting Recess**

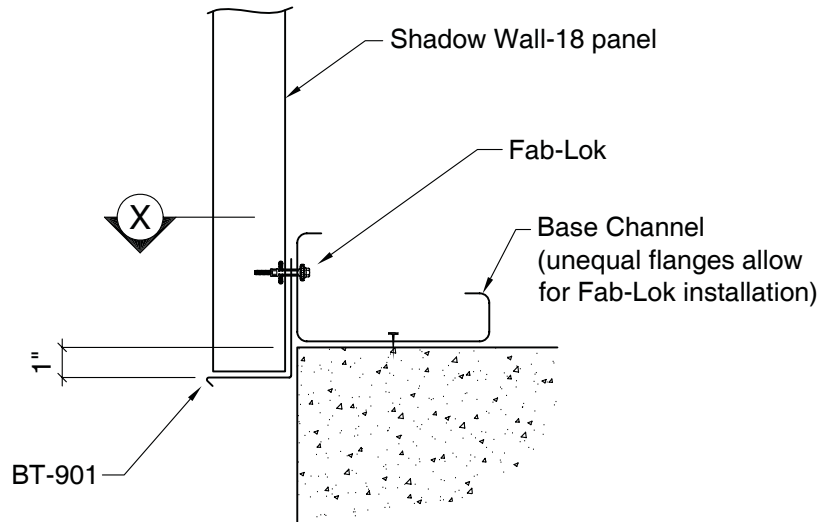

**Without Sheeting Recess**



# Shadow Wall-18

## SUPER SPAN EAVE DETAILS

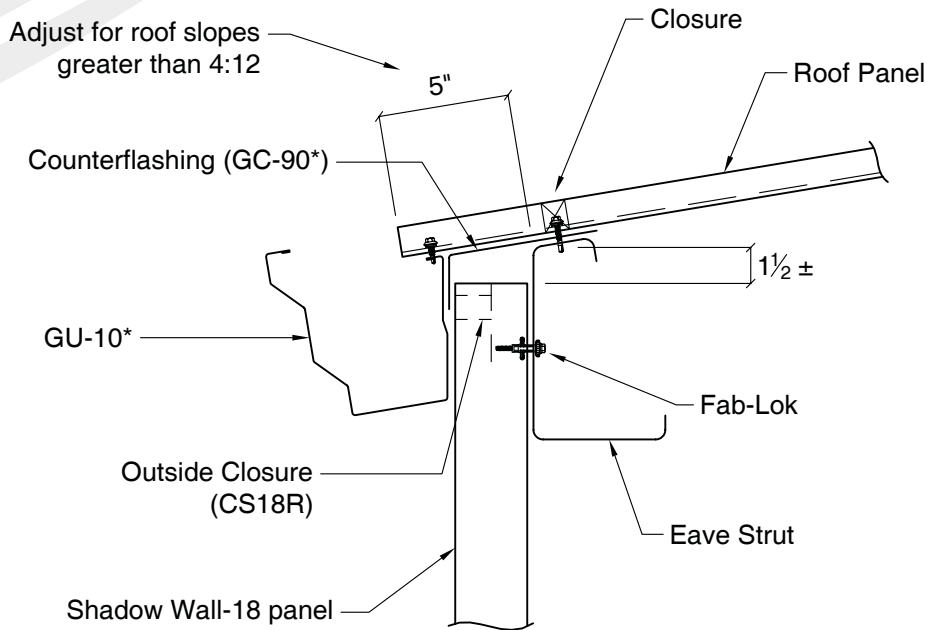

**With Gutter**

\* Indicates Roof Slope

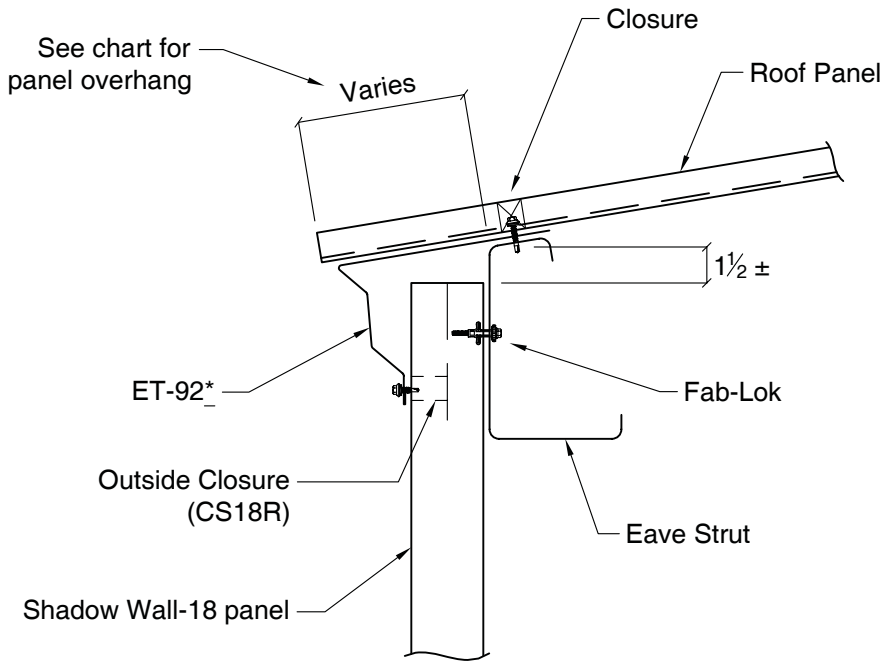

**With Eave Trim**

Roof Slope	Req'd Overhang
1:12	6½"
2:12	7"
3:12	7½"
4:12	8"
5:12	8½"
6:12	9"



# Shadow Wall-18

## SUPER SEAM EAVE DETAILS

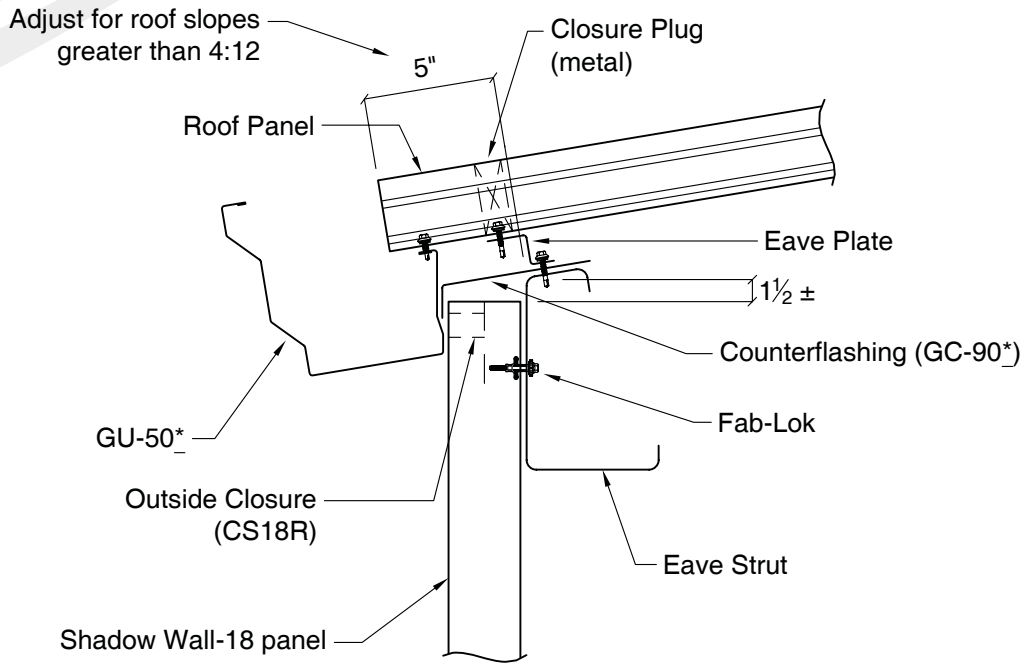

**With Gutter**

\* Indicates Roof Slope  
 \_ Indicates Roof Slope

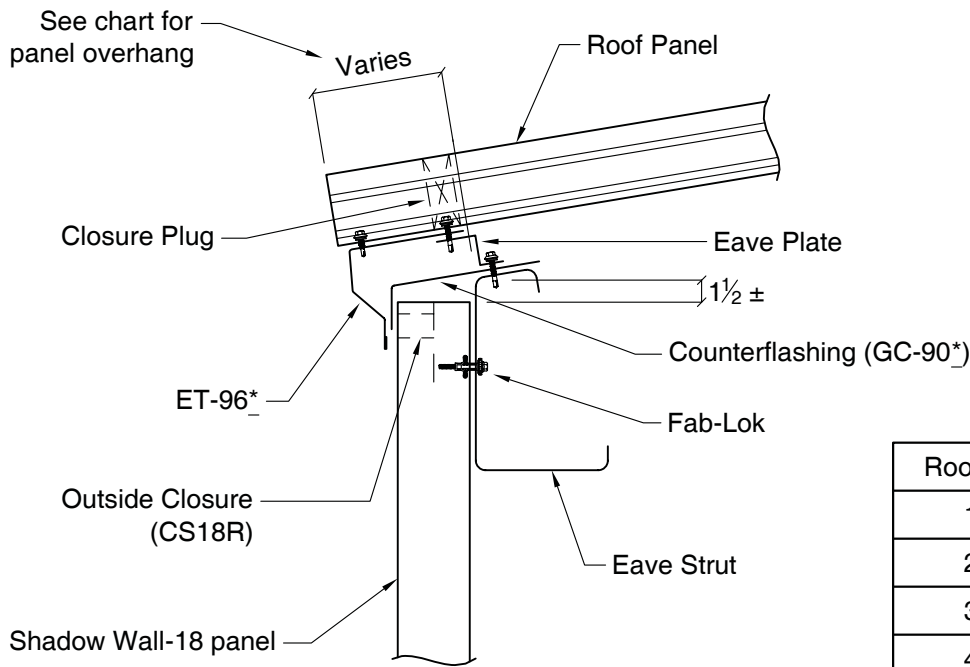

**With Eave Trim**

Roof Slope	Req'd Overhang
1:12	5"
2:12	5½"
3:12	5¾"
4:12	6¼"
5:12	6½"
6:12	7"



**Shadow Wall-18**

**WEATHER PANEL EAVE DETAILS**

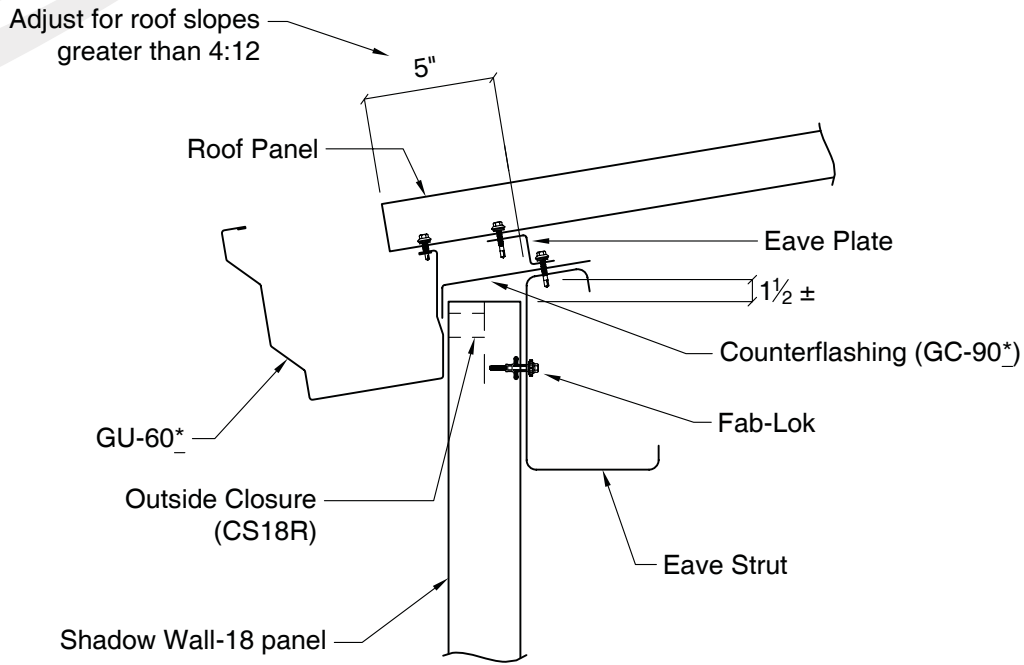

**With Gutter**

\* Indicates Roof Slope  
 \_ Indicates Panel Overhang

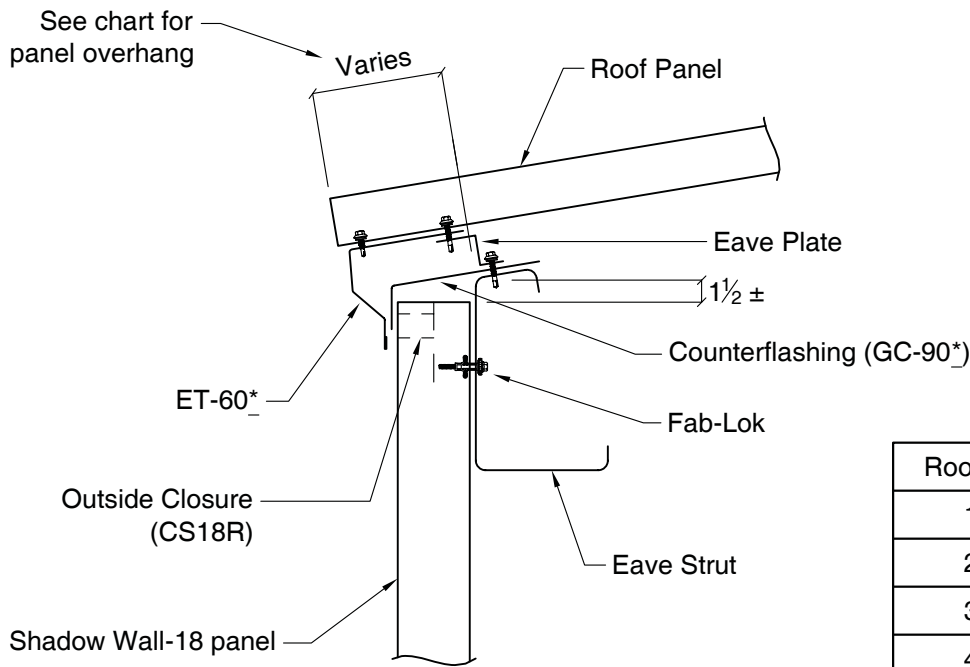

**With Eave Trim**

Roof Slope	Req'd Overhang
1:12	5"
2:12	5½"
3:12	5¾"
4:12	6¼"
5:12	6½"
6:12	7"



# Shadow Wall-18

## RAKE DETAILS

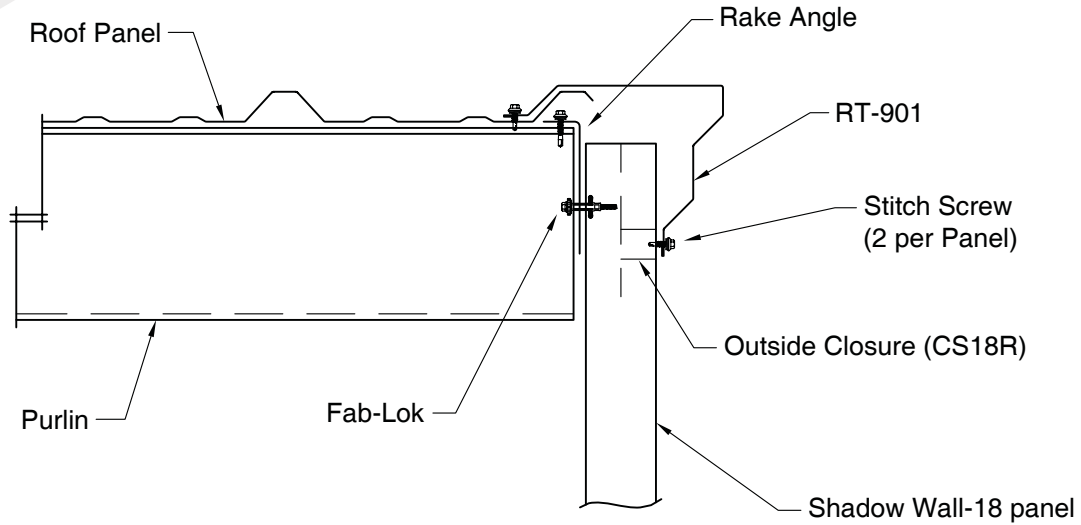

**Super Span Roof**

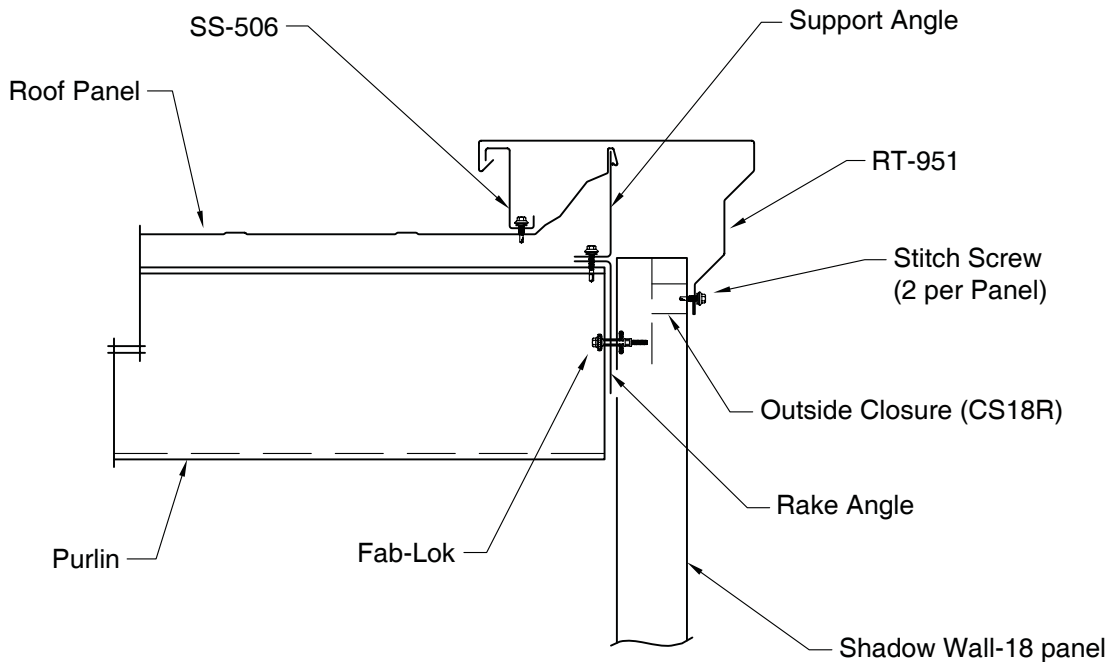

**Super Seam-II or Super Seam-Plus Roof**  
(Weather Lok-16 and Weather Snap-16 similar)



For the most current information available, visit our Web Site at [www.whirlwindsteel.com](http://www.whirlwindsteel.com)

**WHIRLWIND STEEL BUILDINGS, INC.:**

**HOUSTON PLANT:**

8234 HANSEN ROAD  
HOUSTON, TX 77075  
(713) 946-7140 Houston  
(800) 324-9992 U.S. Wats  
(832) 553-4600 Fax

**WHIRLWIND BUILDING COMPONENTS:**

**HOUSTON PLANT:**

8234 HANSEN ROAD  
HOUSTON, TX 77075  
(713) 946-7140 Houston  
(800) 324-9992 U.S. Wats  
(832) 553-4700 Fax

**LITHIA SPRINGS PLANT:**

2175 SWEETWATER INDUSTRIAL BLVD.  
Lithia Springs, GA 30122  
(770) 739-8339 Lithia Springs  
(800) 363-8142 U.S. Wats  
(770) 739-1226 Fax

**CLAREMORE OFFICE:**

2450 E.L. ANDERSON BLVD.  
Claremore, OK 74017  
(918) 343-1973 Claremore  
(877) 875-0077 U.S. Wats  
(918) 343-7114 Fax

**MINNESOTA:**

500 WHIRLWIND DR.  
FREEPORT, MN 56331  
(320) 836-7200 Phone  
(888) 836-7203 U.S. Wats  
(320) 836-7201 Fax